

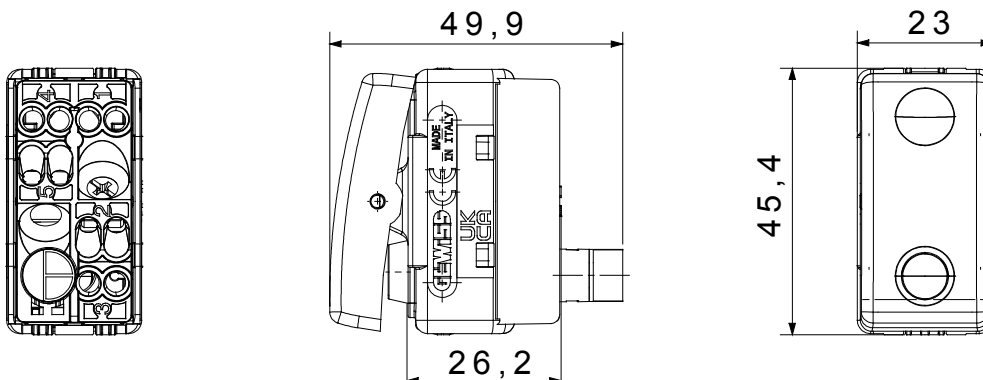

The System modular devices allow the creation of infinite combinations of devices and plates, through a complete range that covers all design, functional and installation needs. Colours and finishes: satin black, elegant and classy. The range includes control units, socket-outlets, breakers, indicators, connectors and devices for the control, safety and comfort of your home.

Catégorie	Bouton-poussoir	Bouton	Avec lentille neutre remplaçable
Symbole	-	Couleur	Noir
Description	1P NO - 10 A lumineux	Tension	250 V ca
Unité de signalisation	LED 12/24Vac/dc (0,4W) white color	Norme	EN 60669-1
Tenue à la tension d'essai	2000 V à 50 Hz pendant 1 minute	Résistance d'isolement	> 5 MOhm
Bornes de câblage	À vis	Endurance (Nbre de manœuvres)	40 000 à In 250 V ca cosφ=0,6
Thermopression avec bille	125 °C	Test du fil incandescent	850 °C
Résistance des bornes à la traction des câbles	> 50 N	Capacité de serrage des bornes câbles souples (mm <sup>2</sup> )	min. 0,75 - max. 2x4
Capacité de serrage des bornes câbles rigides (mm <sup>2</sup> )	min. 0,5 - max. 2x2,5	Nb modules System	1
Matière	Technopolymère	Electrocod	0130

### DIMENSIONS



### SYMBOLE TECHNIQUE



### NORMES ET HOMOLOGATIONS

