

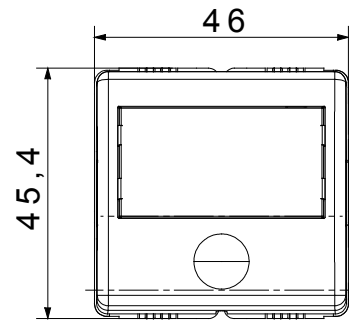

The System modular devices allow the creation of infinite combinations of devices and plates, through a complete range that covers all design, functional and installation needs. Colours and finishes: satin black, elegant and classy. The range includes control units, socket-outlets, breakers, indicators, connectors and devices for the control, safety and comfort of your home.

Kategorie	Taster	Typ	Namensschild
Farbe	Schwarz	Beschreibung	1P S - 10A
Spannung	250 V ac	Norm	EN 60669-1
Widerstand bei Prüfspannung	2000 V bei 50 Hz für 1 Minute	Isolationswiderstand	> 5 MOhm
Anschlussklemmen	Mit Schrauben	Anzahl Betätigungen (Änderung Schaltstellung).	40.000 bei In 250 V ac cosφ=0,6
Haltekraft Klemme	> 50 N	Anschluss feindrätig (mm²)	min. 0,75 - max. 2x4
Anschluss massiv (mm²)	min. 0,5 - max. 2x2,5	Leuchtmittel	Soffittenlampe S6x36 mm
Kugeldruckprüfung	125 °C	Lampen spannung	12-24V ac/dc
Glühdrahtprüfung	850 °C	Leistung Lampe	2 W
Anz. SYSTEM Module	2	Material	Technopolymer
Electrocod	0130		

Abmessungen

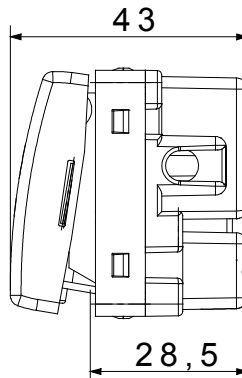
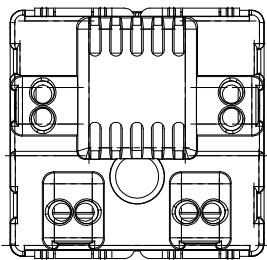

Technische Symbole



Normen / Richtlinien

