



Systems of accessories for electrical installations used for residential, tertiary and industrial applications. The system consists of fasteners for pipes and cables, cable fittings, accessories for rigid pipes (RK Series) and flexible conduit (DF Series). The system include also a wide variety of cable ties (52FS Range) and terminal blocks (44 Range).

|                                 |  |                       |              |
|---------------------------------|--|-----------------------|--------------|
| Colour                          | Grey RAL 7035                            | IP degree             | -            |
| Material                        | Shockproof polymer                       | Fixing                | Post bracket |
| For external conduits (mm)      | 40                                       | Glow Wire Test        | 750 °C       |
| Wall-conduit axis distance (mm) | 32                                       | Operating temperature | -5 +60 °C    |
| Type of material                | Halogen free in compliance with EN 50642 | Electrocod            | 21221        |
| Standard                        | EN 61386-1 (when applicable)             |                       |              |

#### BEHAVIOUR WITH CHEMICAL AND ATMOSPHERIC AGENTS

| Saline solution | Acids              |                    | Bases        |           | Solvents  |           |           |               | Mineral oil | UV rays            |
|-----------------|--------------------|--------------------|--------------|-----------|-----------|-----------|-----------|---------------|-------------|--------------------|
|                 | Concentrated       | Diluted            | Concentrated | Diluted   | Hexane    | Benzol    | Acetone   | Ethyl alcohol |             |                    |
| Resistant       | Limited resistance | Limited resistance | Resistant    | Resistant | Resistant | Resistant | Resistant | Resistant     | Resistant   | Limited resistance |

#### DIMENSIONAL

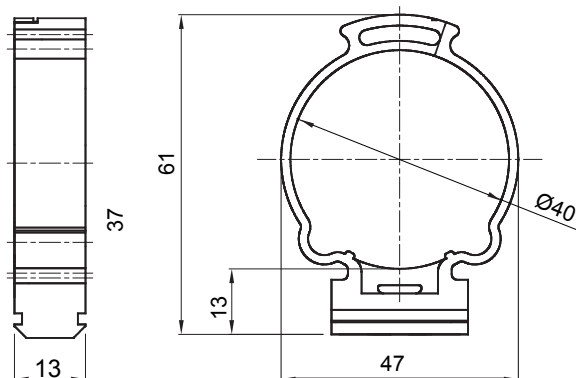

#### TECHNICAL SYMBOLOGY

IP

GWT

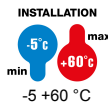

HF

Halogen free in compliance with EN 50642

#### STANDARDS/APPROVALS

