

The System modular devices allow the creation of an infinite combination of devices and plates, thanks to a complete range that covers all design, functional and installation needs. Colours and finishes: bright and versatile glossy white, and elegant and classy satin black. Ideal for flush-mounted solutions (for rectangular or square boxes), surface-mounted solutions and special applications. The range includes control units, socket-outlets, breakers, indicators, connectors and devices for the control, safety and comfort of the home.

Typ	Residual current breaker with overcurrent protection	Typ	Bezpieczeństwo
Grupa	Ochrona	Opis	Dwa bieguny (1P+N)
Krzywa	C	Class	A
wyjściowe	230V - 50 / 60 Hz	Idn	10 mA
Prąd znamionowy (A)	16	Wyłączalność zdolność	3 kA
Kolor	Biały	Norma	CEI 23-95
Liczba SYSTEM Moduły	2	Materiał	Technopolimerowy
Electrocod	0131		

DIMENSIONAL

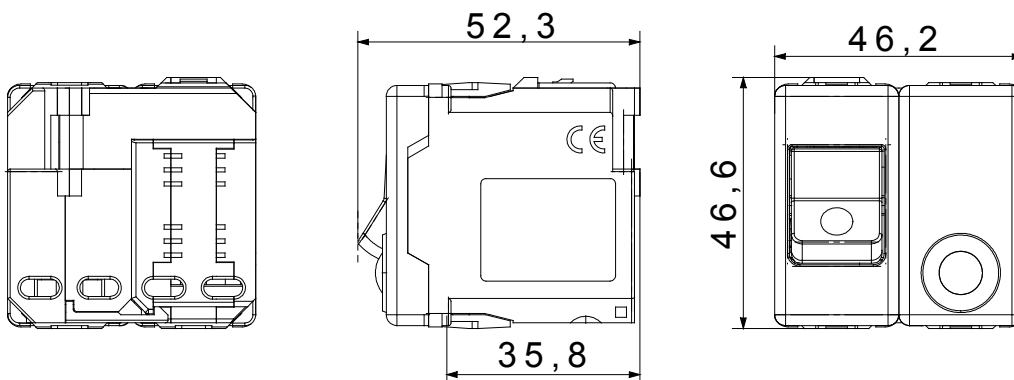

STANDARDS/APPROVALS

