



Wired pedestals QMC range, certified for use on construction sites, are extremely versatile and offer a high degree of personalisation. Thanks to the handle built into the head, they can easily be moved all over the site without any need for additional supports. Each pedestal is equipped with stainless steel tear-proof cable-fastening hooks, enclosure with transparent window, and 5 meters of cable with relative plug.

Type	Q-MC ACS	board type	Wired
Colour	Light blue	Weight (kg)	14
Accordance with Standards	EN 61439-4 (ACS)	Characteristics	UV resistance (EN 62208)
IP degree	IP56	Mechanical resistance	IK09
Glow wire test	650 °C	Thermo-pressure with ball	70 °C
Insulation class	II	Power supply	Mobile plug
No. of poles	3P+N+E	MCB'S MT main RCCB	RCCB 40A 4P 0,03A - AC type
Circuits protection	MCB	Socket-outlet 2P+E 16A - IEC 309	7
Cable length	5 m		

BEHAVIOUR WITH CHEMICAL AND ATMOSPHERIC AGENTS

Saline solution	Acids		Bases		Solvents				Mineral oil	UV rays
	Concentrated	Diluted	Concentrated	Diluted	Hexane	Benzol	Acetone	Ethyl alcohol		
Resistant	Limited resistance	Resistant	Limited resistance	Resistant	Limited resistance	Limited resistance	Limited resistance	Resistant	Limited resistance	Resistant

DIMENSIONAL

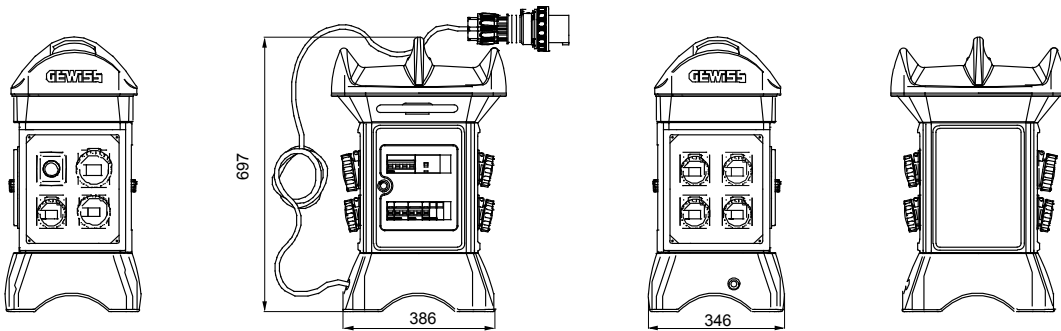

TECHNICAL SYMBOLOGY



EN 61439-4 (ACS)



UV resistance (EN 62208)

IP

IP56

GWT

650 °C



70 °C



II

IK09

STANDARDS/APPROVALS

