

IP degree		IP66	Mechanical resistance	> IK10
For Modular bases	GW66696 - GW66697 - GW66698 - GW66781 - GW66782 - GW66783		For back boxes	GW66685
Glow Wire Test		850 °C	Suitable for	Heavy duty
Electrocod		2222	Impact resistance at -20 °C	20 J

DIMENSIONAL

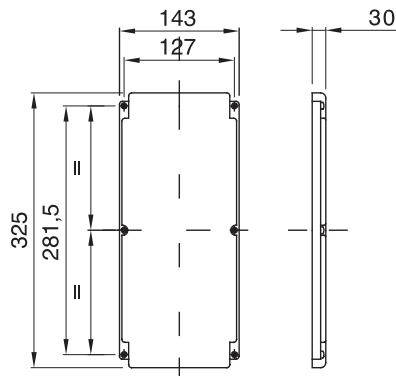

TECHNICAL SYMBOLOGY

IP

IP66

GWT

850 °C

> IK10

STANDARDS/APPROVALS

