

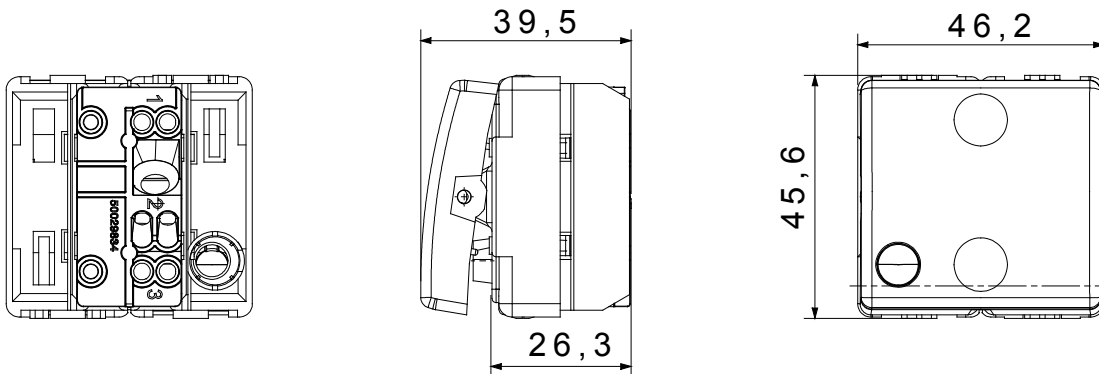

The System modular devices allow the creation of infinite combinations of devices and plates, through a complete range that covers all design, functional and installation needs. Colours and finishes: satin black, elegant and classy. The range includes control units, socket-outlets, breakers, indicators, connectors and devices for the control, safety and comfort of your home.

|   |                              |  |                                |
|---|------------------------------|--|--------------------------------|
| Category  | Reversing switch             | Button key   | With diffuser                  |
| Colour  | Black                        | Description  | 1P - 16 AX - illuminable       |
| Voltage   | 250 V ac                     | Standard   | EN 60669-1                     |
| Resistance at test voltage                                      | 2000 V at 50 Hz for 1 minute | Insulation resistance  | > 5 MOhm                       |
| Wiring terminals  | With screw                   | Prolonged operation switch (no.of position changes)                | 40.000 at In 250 V ac cosφ=0,6 |
| Terminal grip on cable traction                                 | > 50 N                       | Terminal tightening capacity<br>stranded cables (mm <sup>2</sup> ) | min. 0,75 - max. 2x4           |
| Terminal tightening capacity<br>solid cables (mm <sup>2</sup> ) | min. 0,5 - max. 2x2,5        | Thermo-pressure with ball  | 125 °C                         |
| Rated power of 230V LED lamps                                   | 200 W                        | Glow Wire Test   | 850 °C                         |
| No. SYSTEM modules  | 2                            | Material   | Technopolymer                  |
| Electrocod  | 0130                         |  |                                |

### DIMENSIONAL



### TECHNICAL SYMBOLOGY



### STANDARDS/APPROVALS

