

LOWBAY - HIGHBAY - FLOODLIGHTS

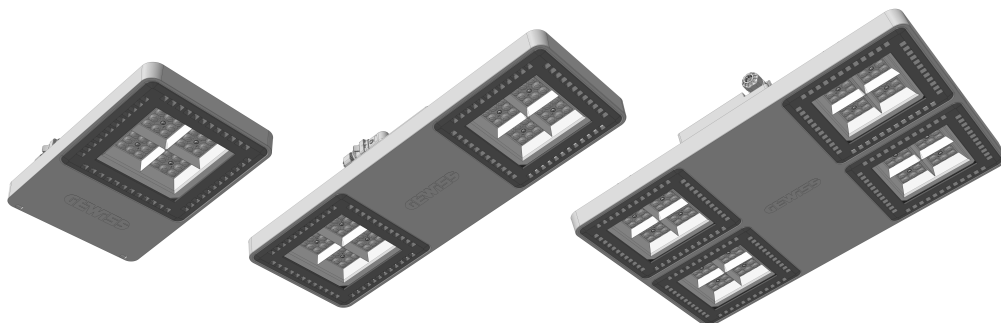

	3,5	0,097 m ²	0,029 m ²
	6,5	0,184 m ²	0,022 m ²
	13,5	0,35 m ²	0,045 m ²

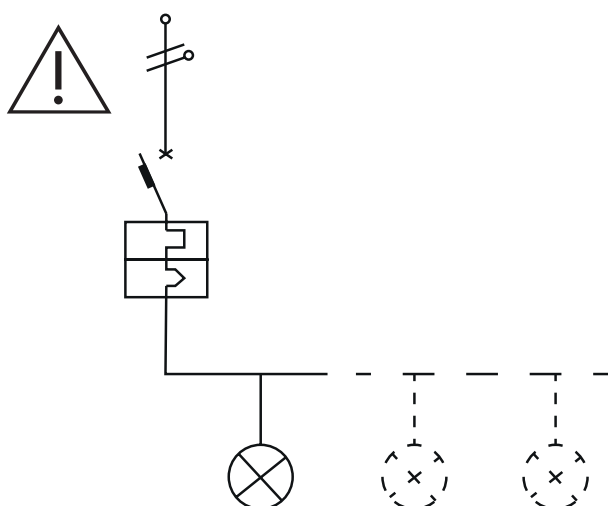

MCB current	10 A	16 A	20 A
Max number of SMART[4] (Type B)			
SMART[4] 1M	12	19	24
SMART[4] 2M	12	19	24
SMART[4] 4M	6	9	12
Max number of SMART[4] (Type C)			
SMART[4] 1M	17	28	35
SMART[4] 2M	14	23	29
SMART[4] 4M	7	11	14
Max number of SMART[4] (Type D)			
SMART[4] 1M	20	32	40
SMART[4] 2M	16	26	33
SMART[4] 4M	8	13	16

LED CCT:	≤ 6500 K		
	RG1:	RG0:	
	Smart[4] 1M / 2M / 4M	Smart[4] 1M	Smart[4] 2M / 4M
ARRAY	100 cm	400 cm	575 cm
90°	50 cm	450 cm	600 cm
60°	100 cm	500 cm	700 cm
30°	20 cm	850 cm	1200 cm
ASYMMETRICAL	20 cm	350 cm	475 cm
ELLIPTICAL	75 cm	425 cm	600 cm

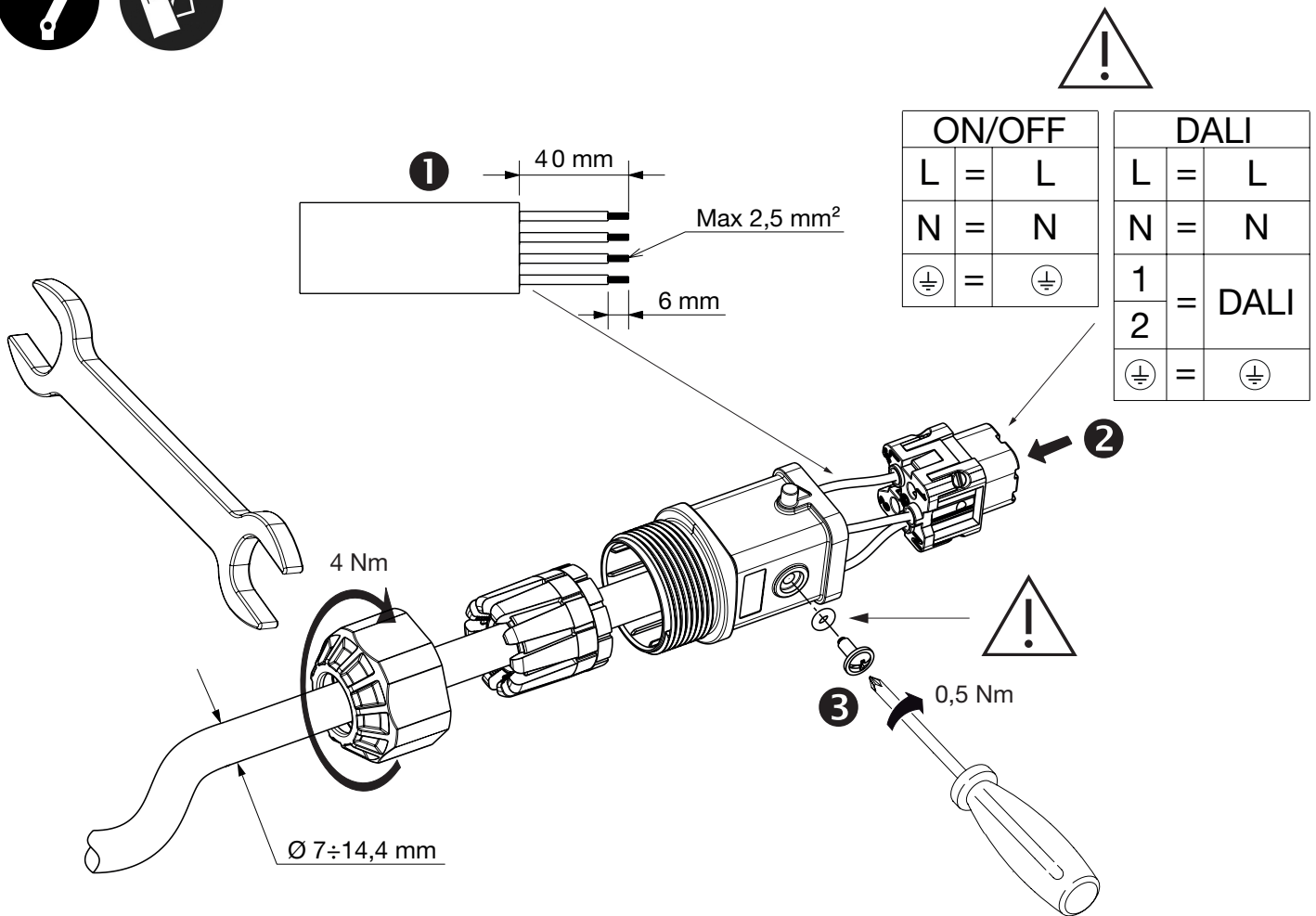
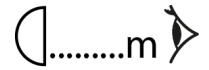

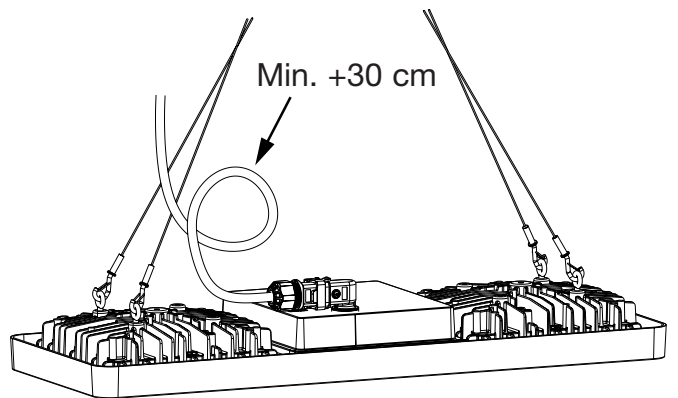
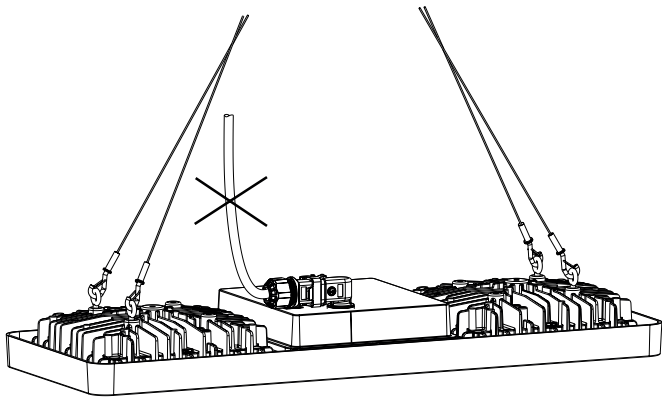
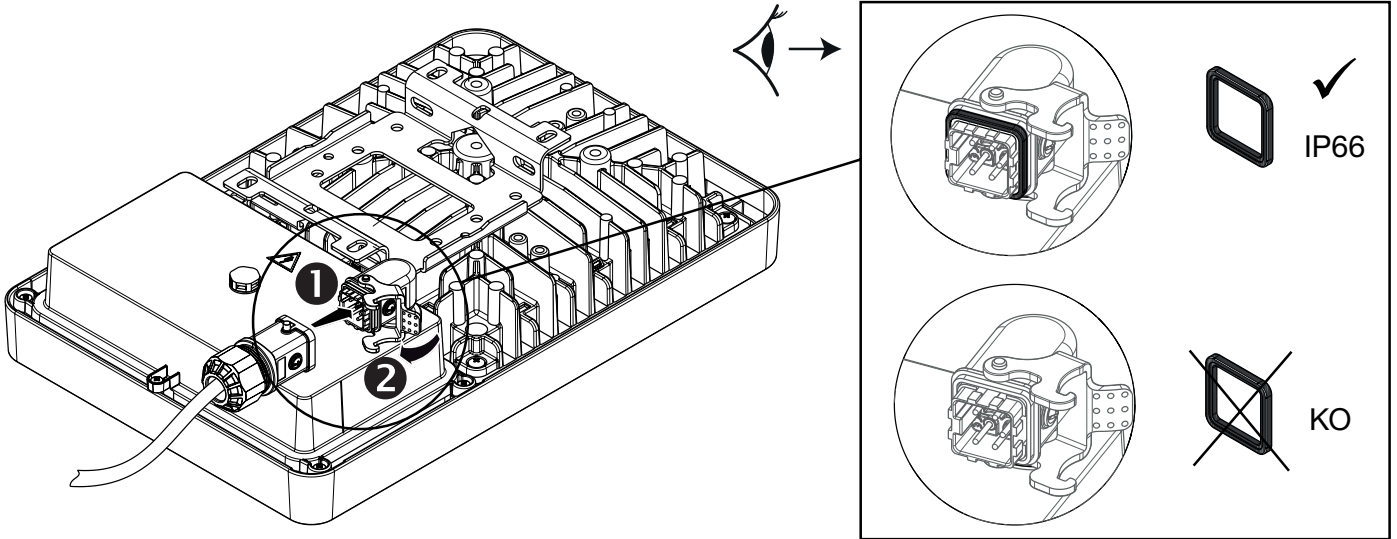

SMART[4] 1M

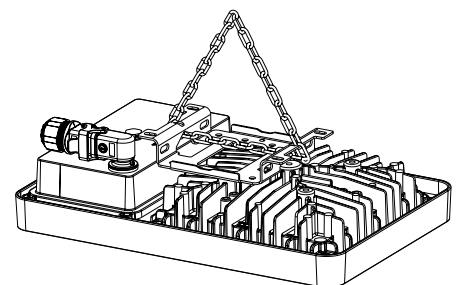
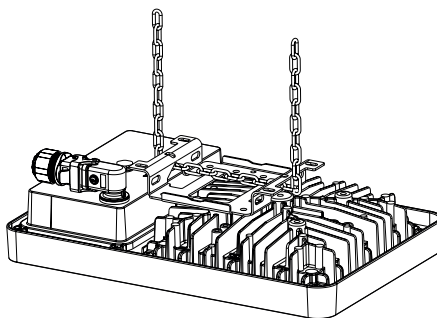
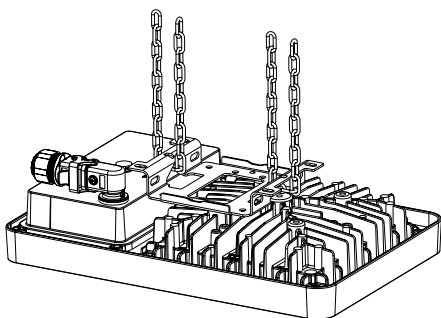
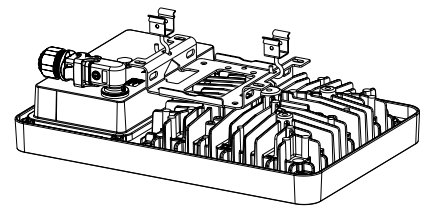
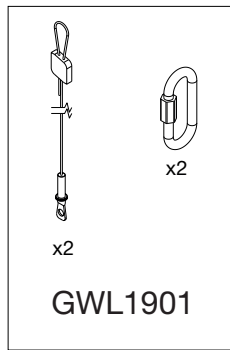
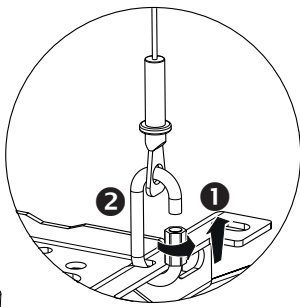
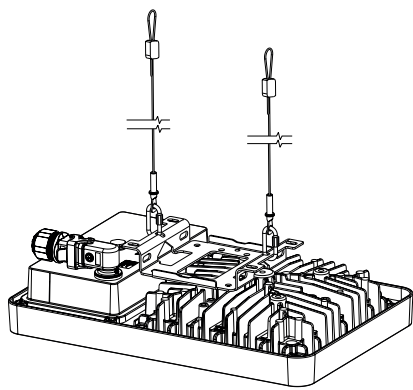
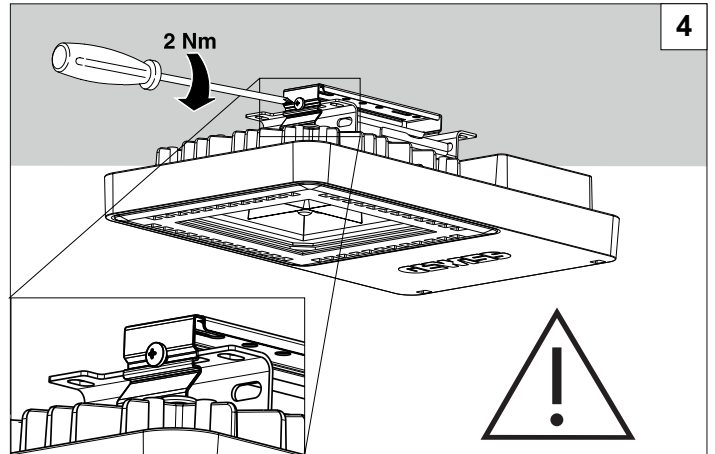
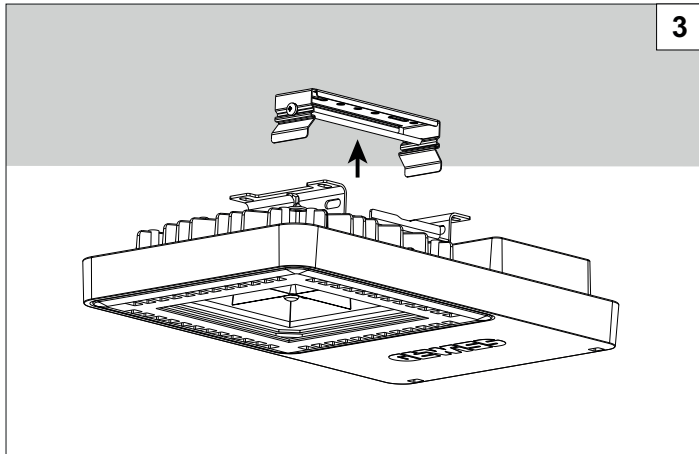
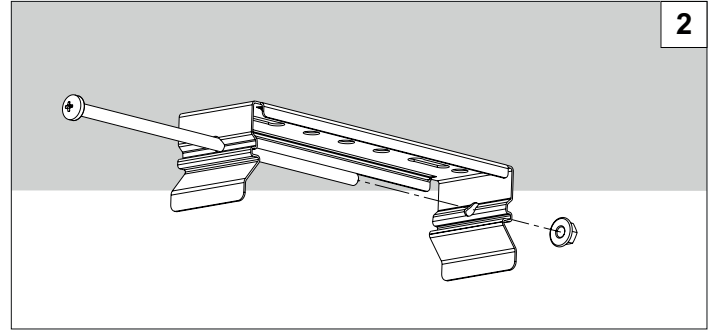
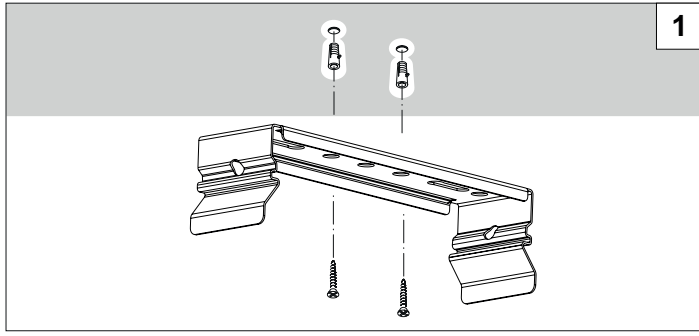

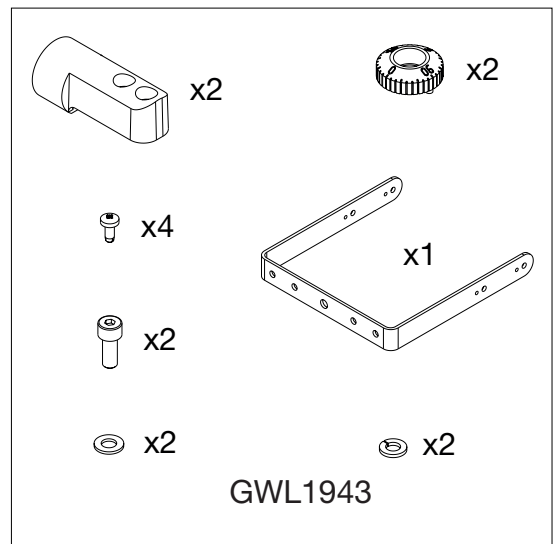
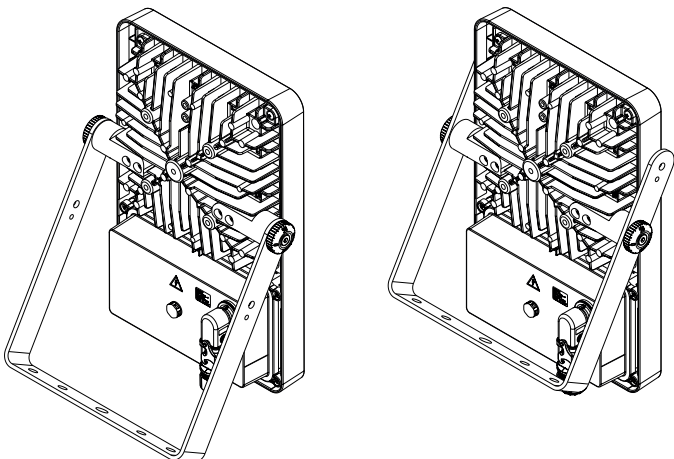
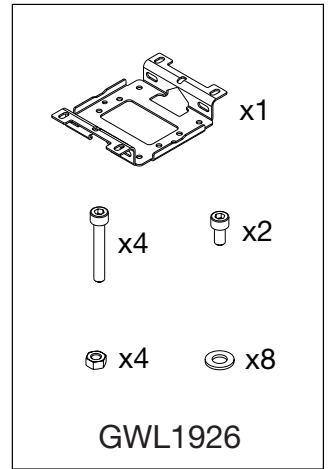
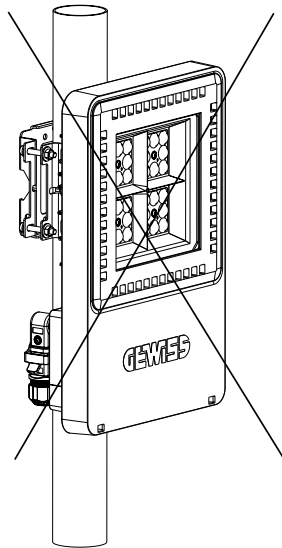
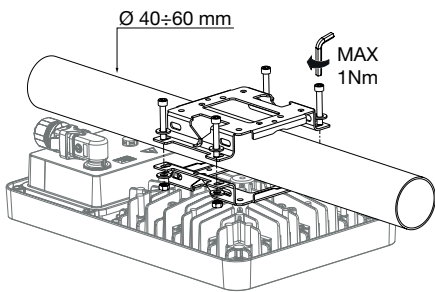
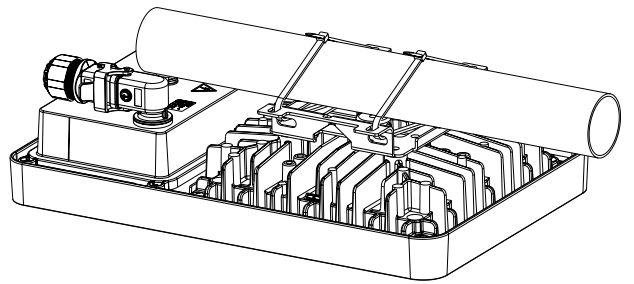
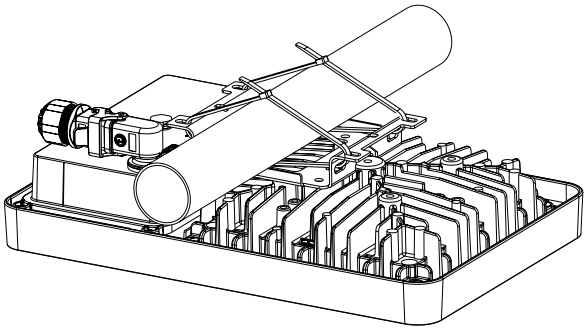
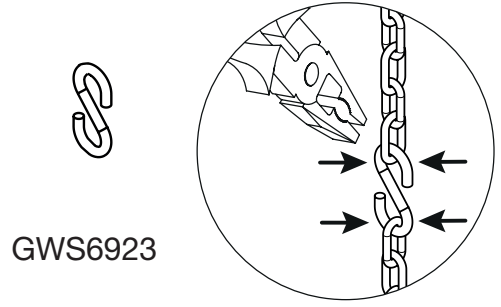

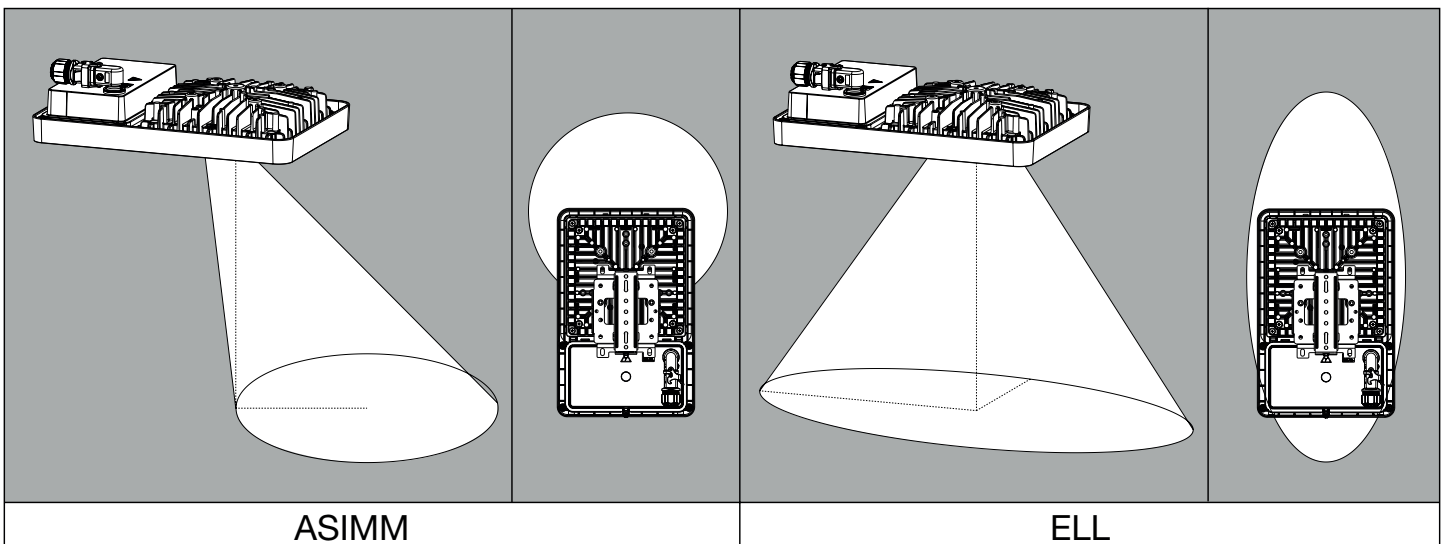
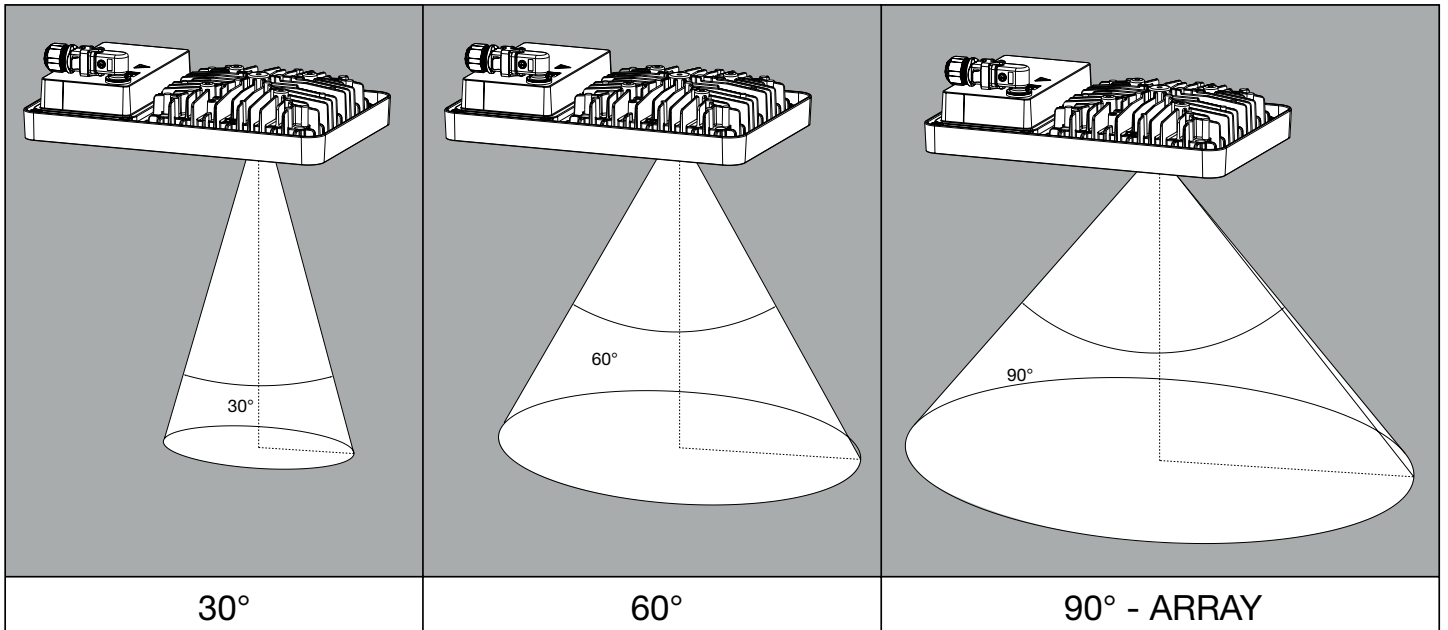
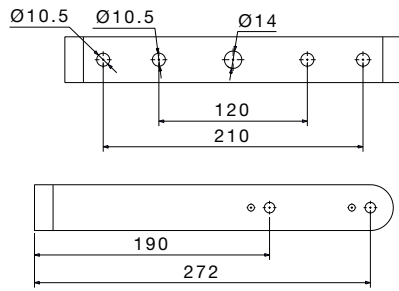
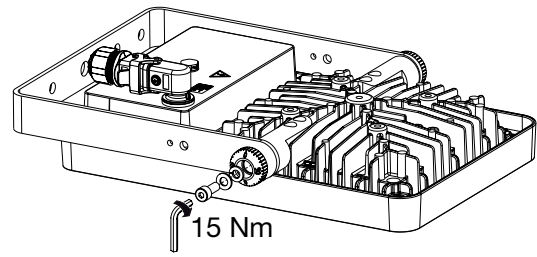
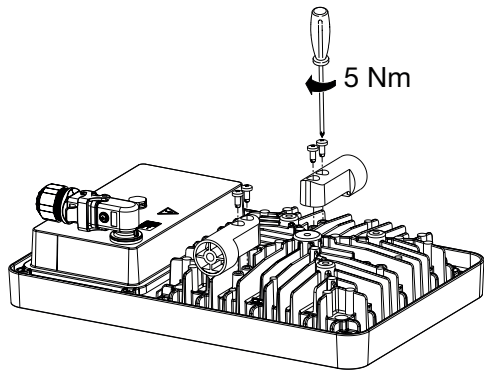

SMART[4] 2M

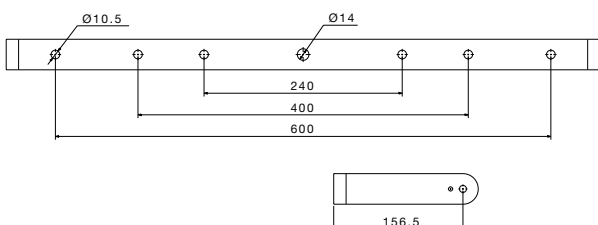
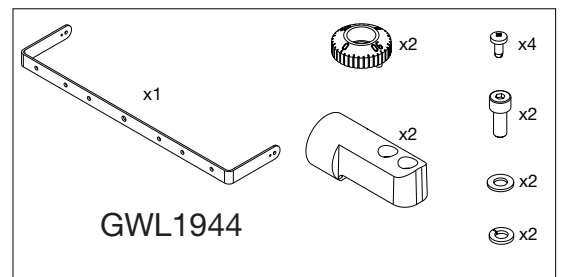
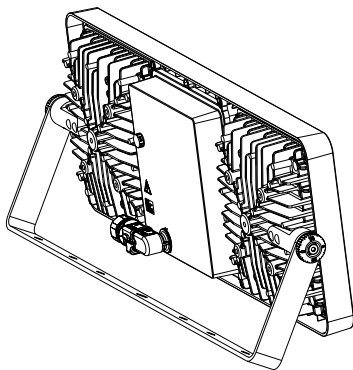
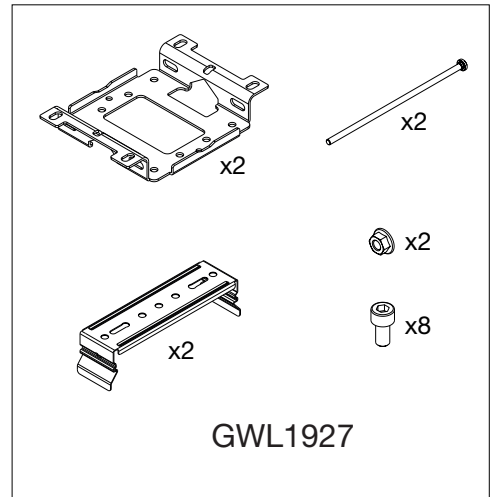
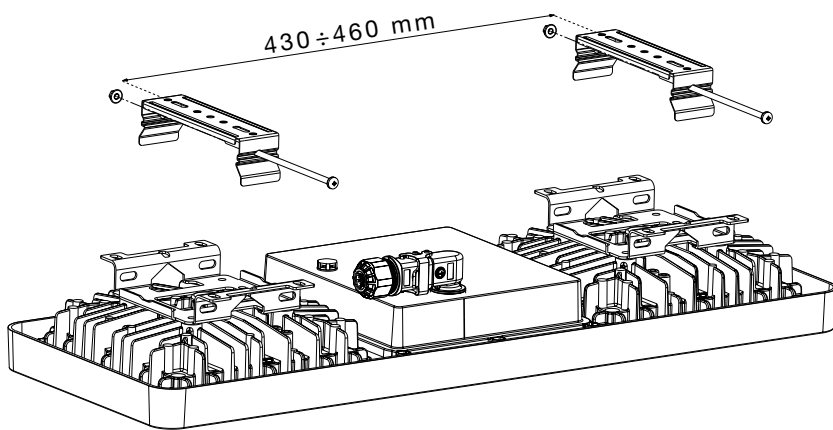
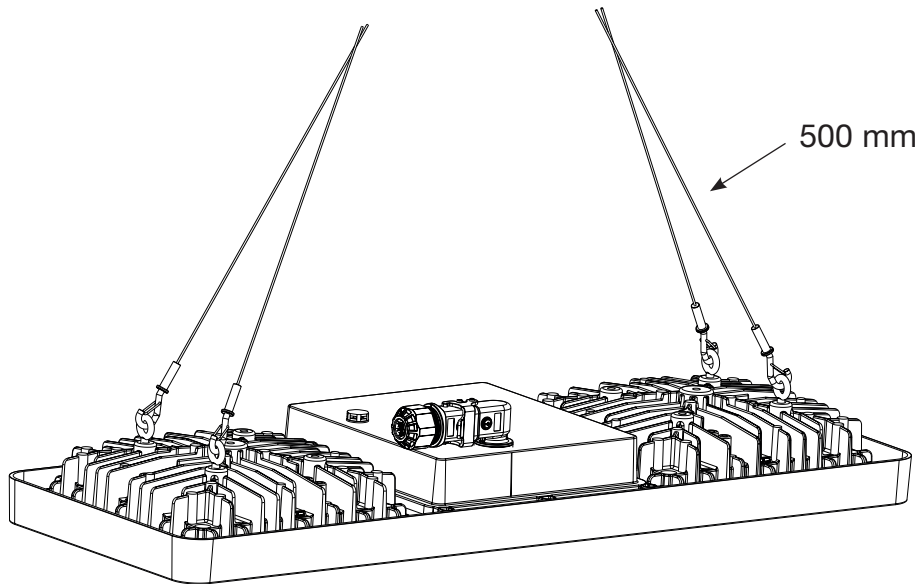

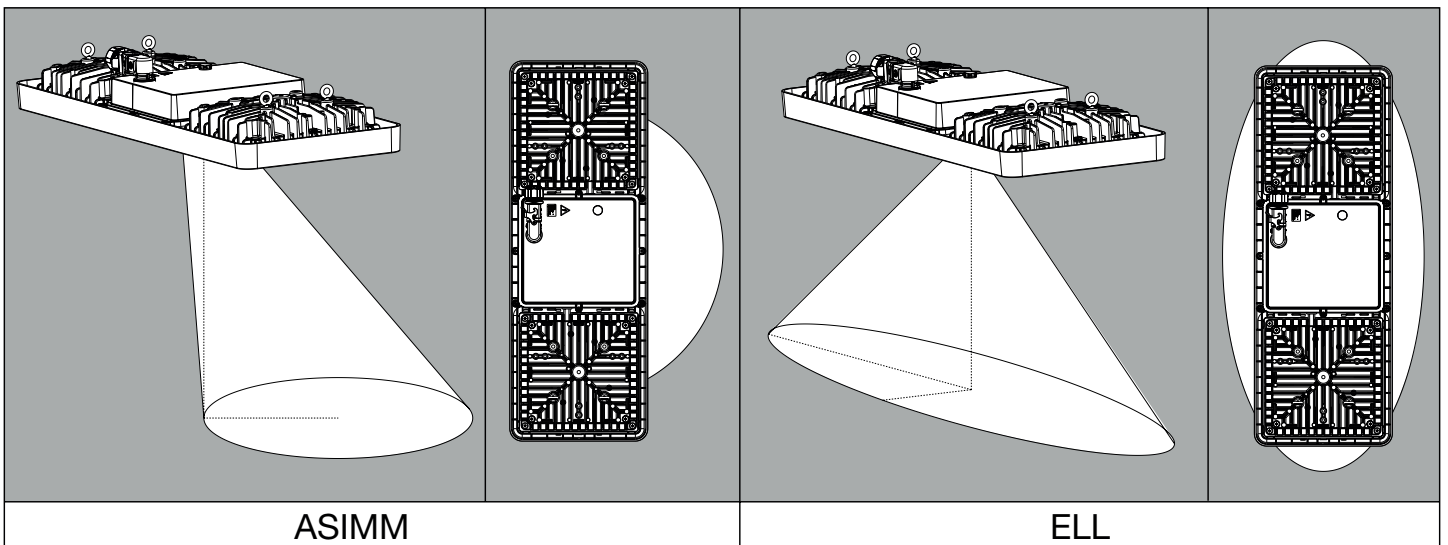
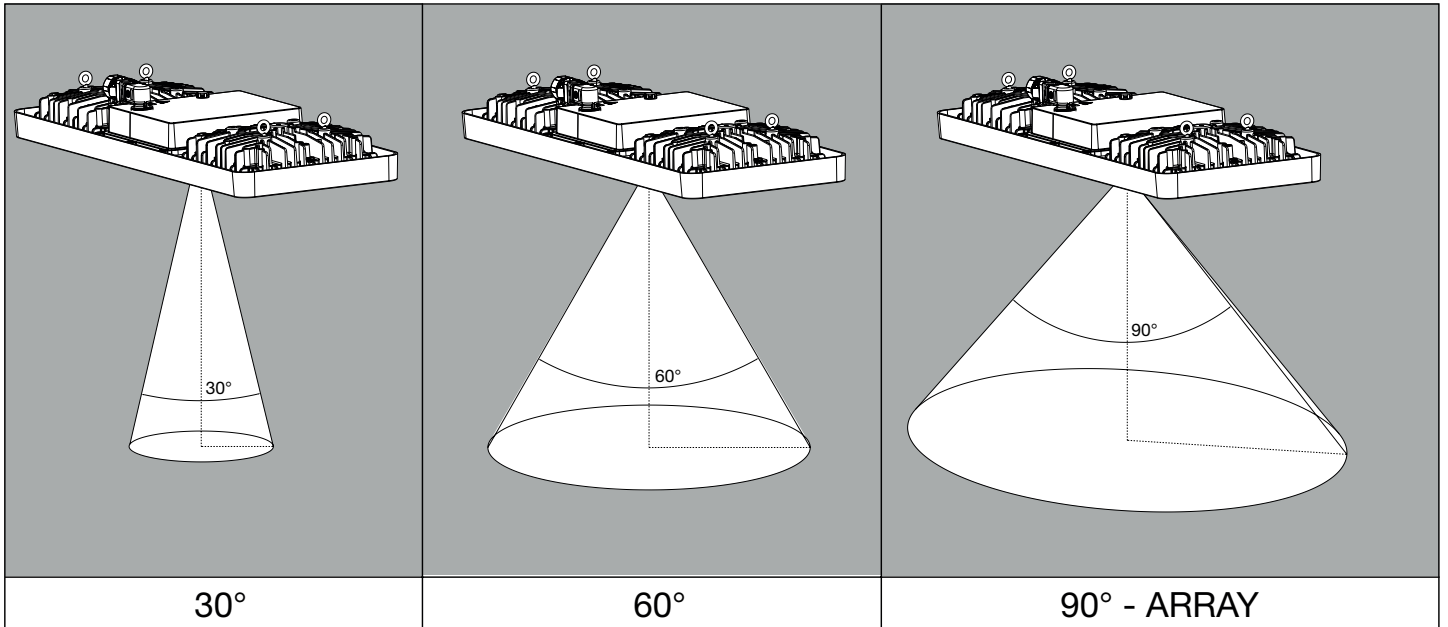
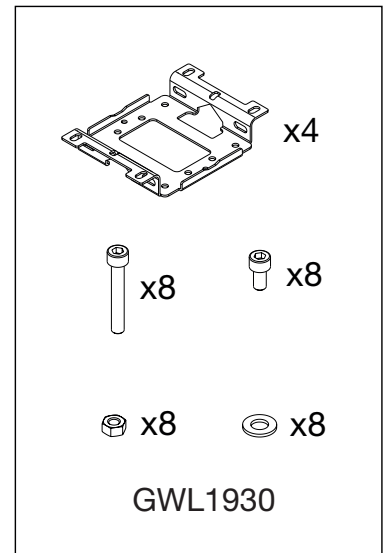
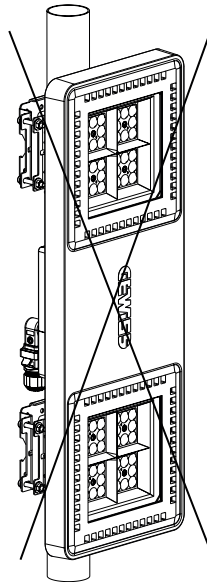
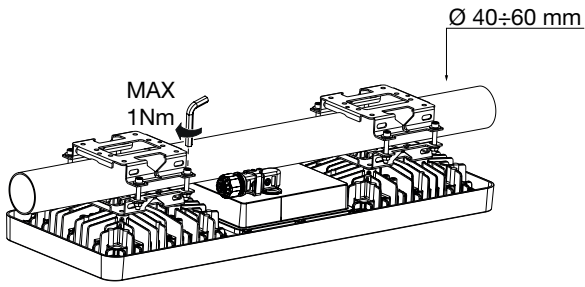

SMART[4] 4M

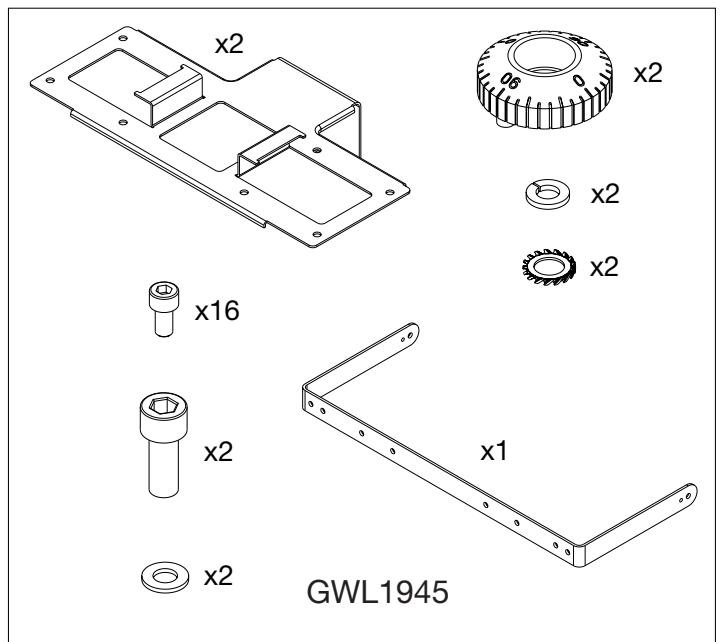
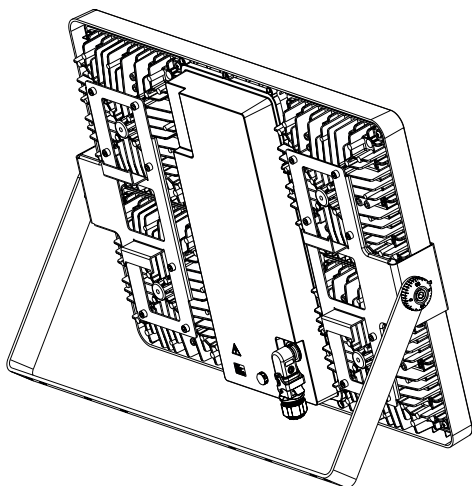
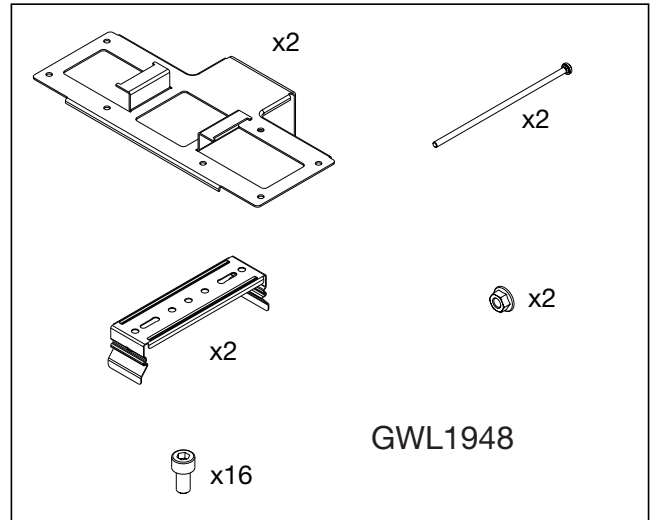
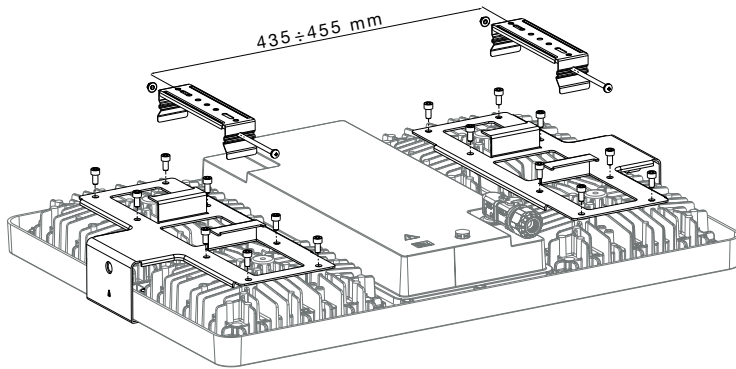
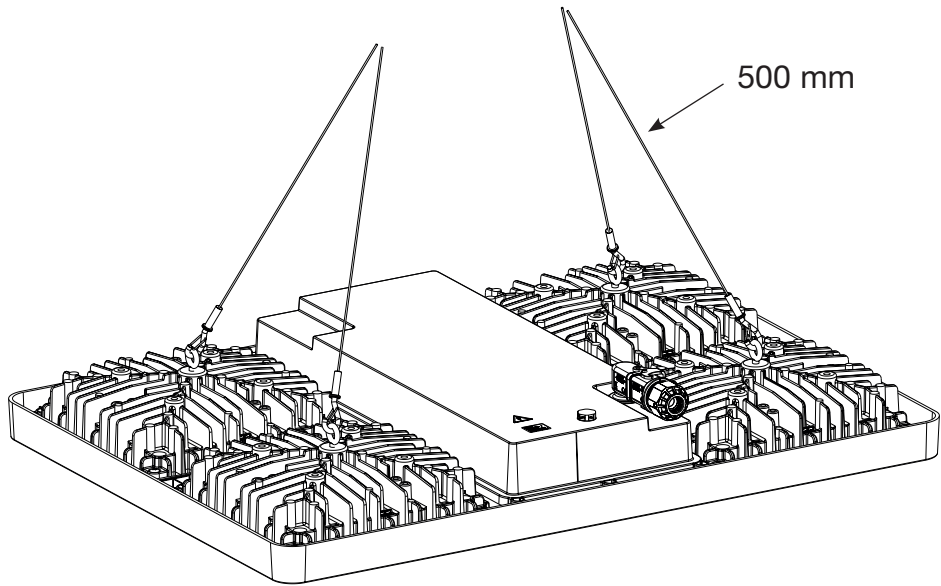

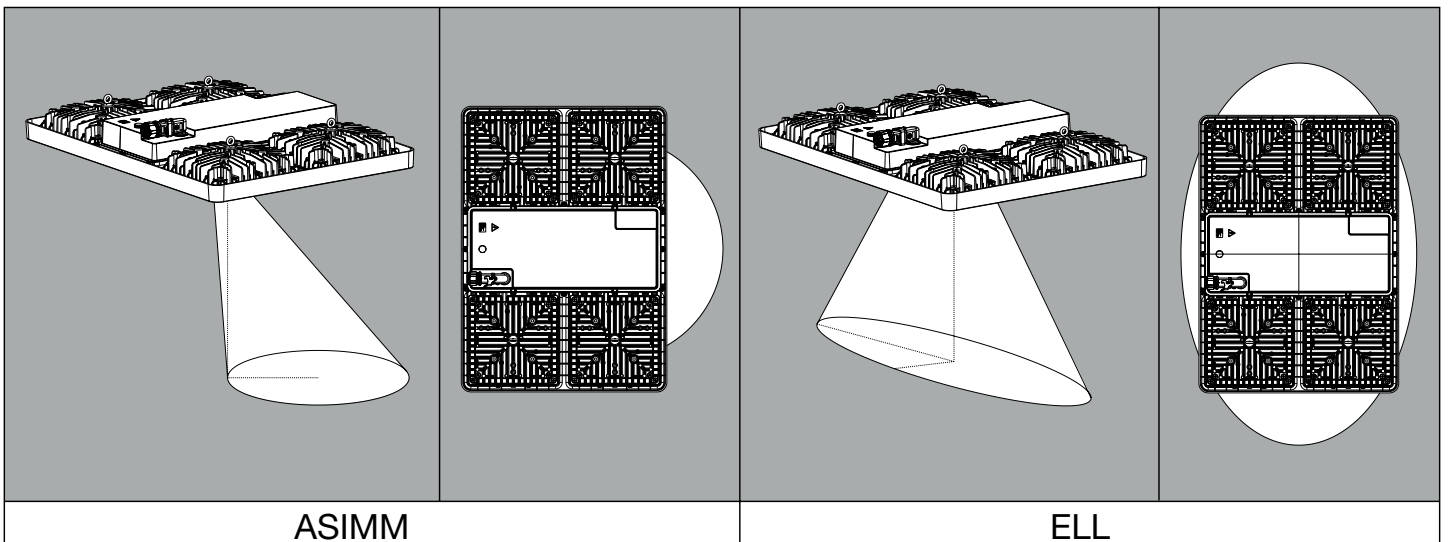
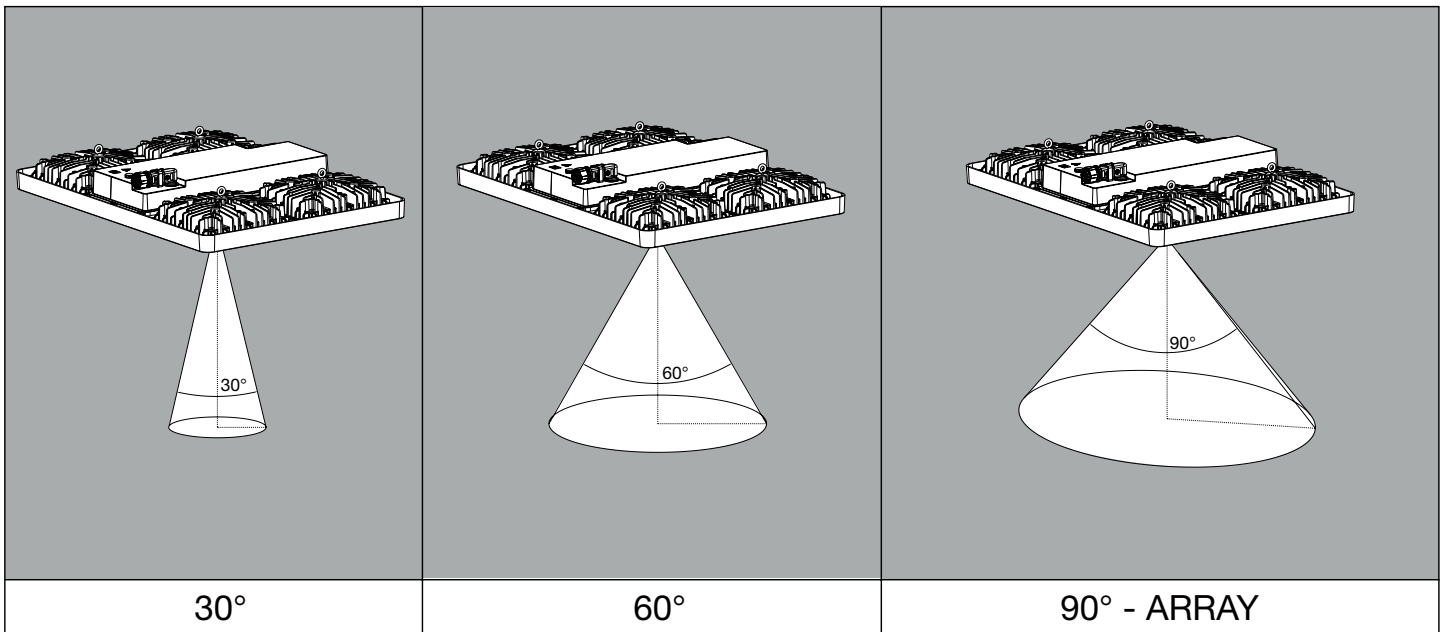
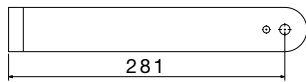
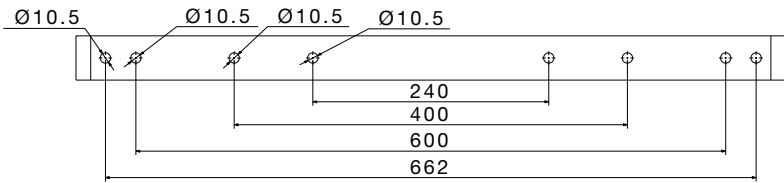
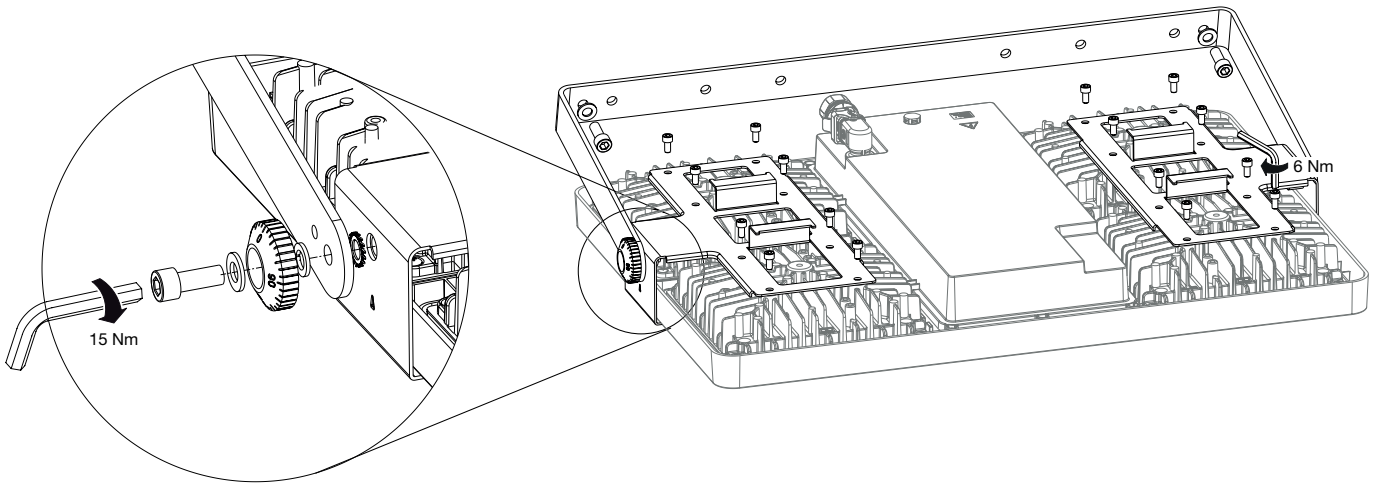

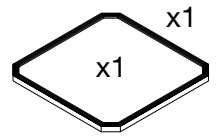
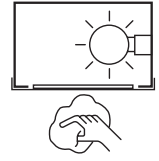
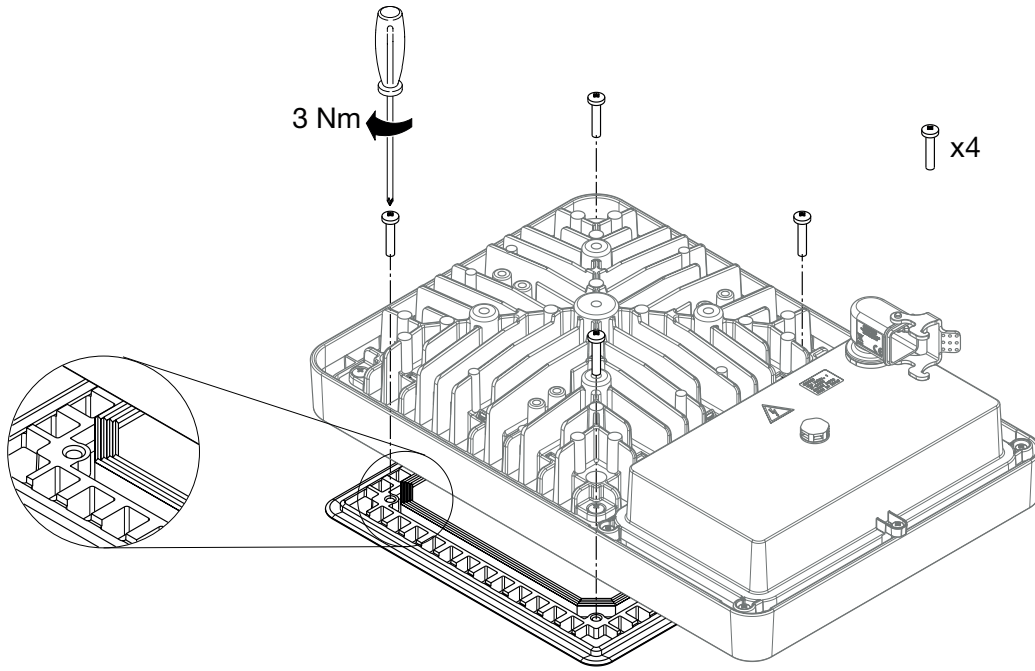

GWL1907



SMART[4] 1M

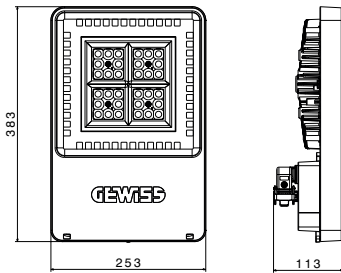

SMART[4] 2M

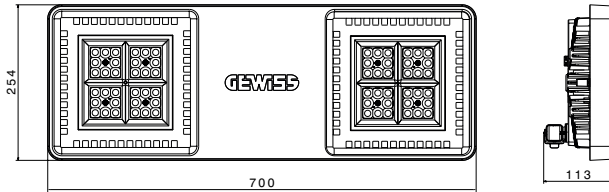

SMART[4] 4M

