

SPATIUMPRO | 3

GEWISS

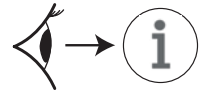
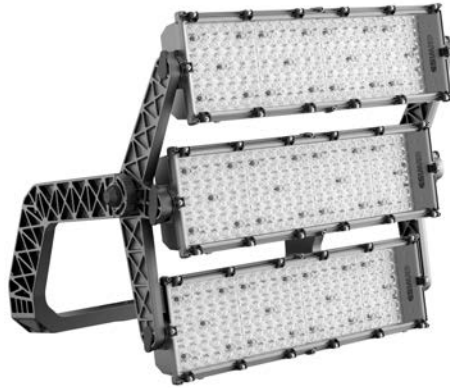

				I	Uout
	29 Kg	0,111 m ²	0,362 m ²	Max 0,95 A	Max 600 V [~]

t_a +50°C	t_a +35°C

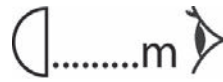

LED CCT		≤ 5700 K	LED CCT		≤ 5700 K
Optics		RG1	Optics		RG1
	A1	12 m		S1	20 m
	45°			20°x80°	
	A2	13 m		C1	20 m
	60°			40°	

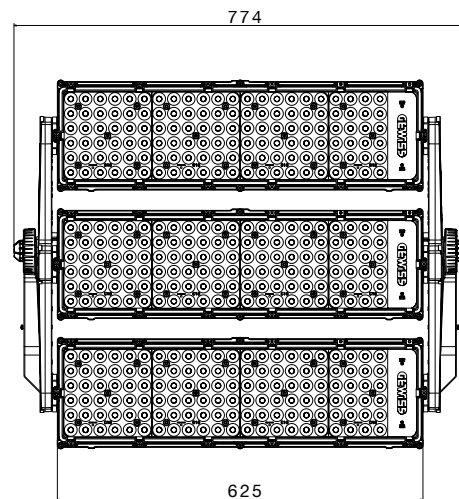
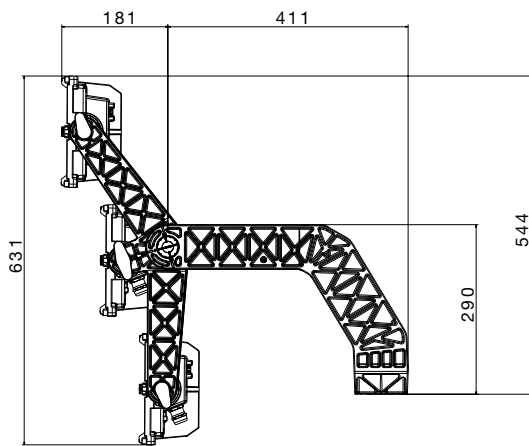

SPATIUMPRO I 3 +

GWP30005 (GWP30037)
GWP30034 (GWP30036)

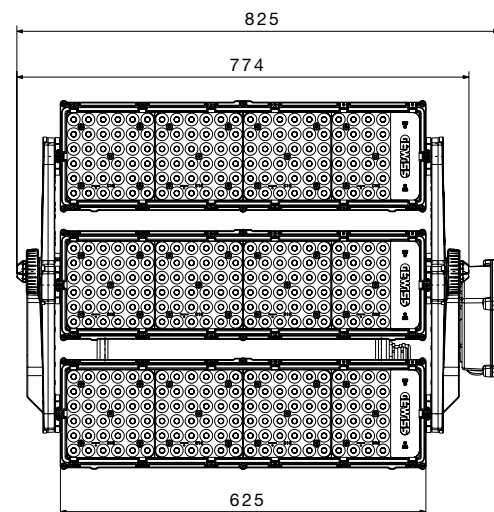
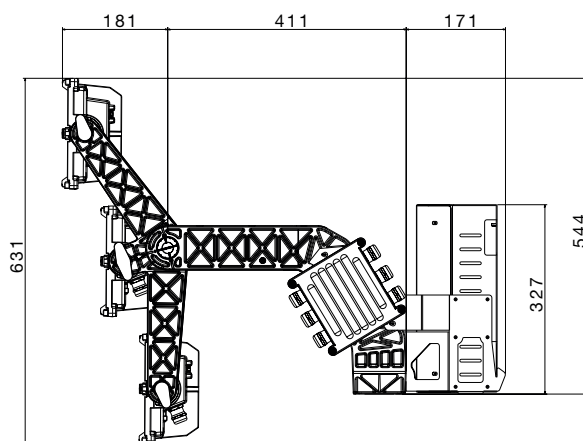
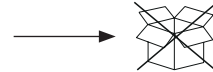

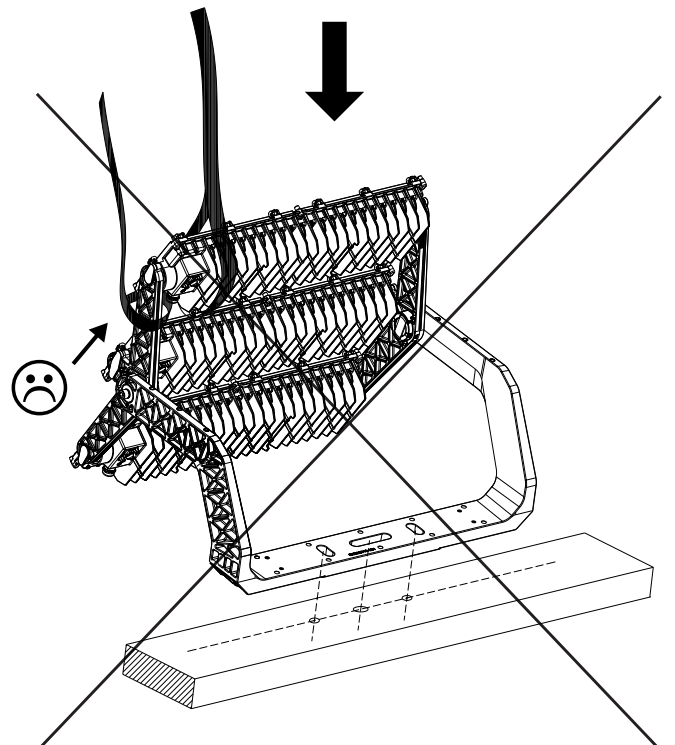
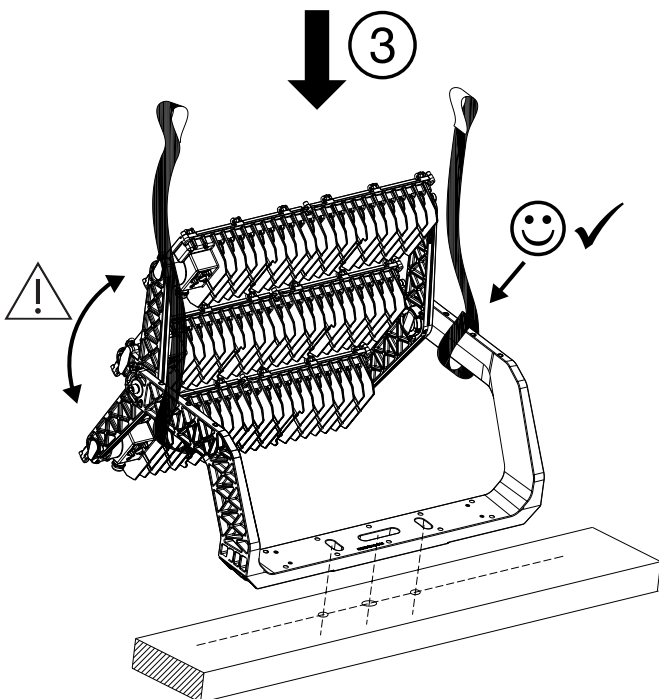
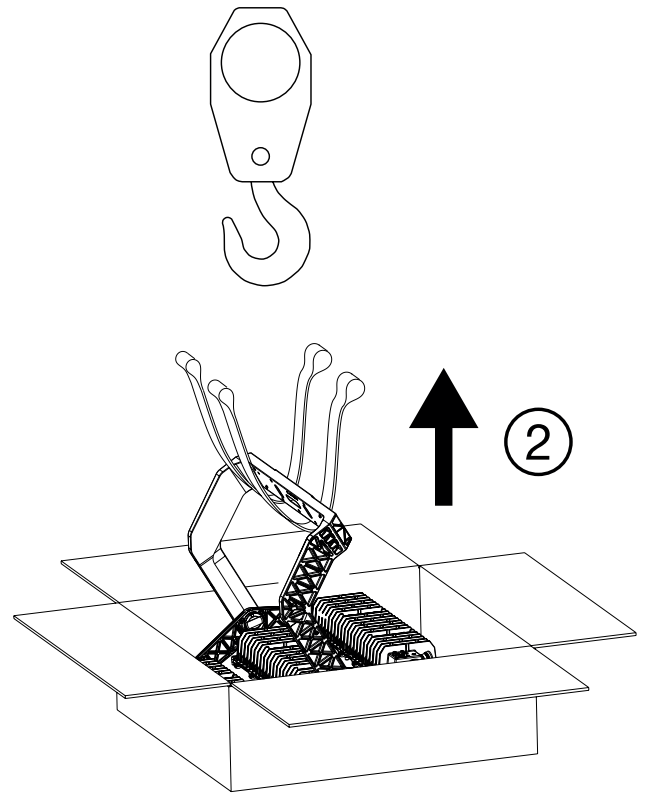
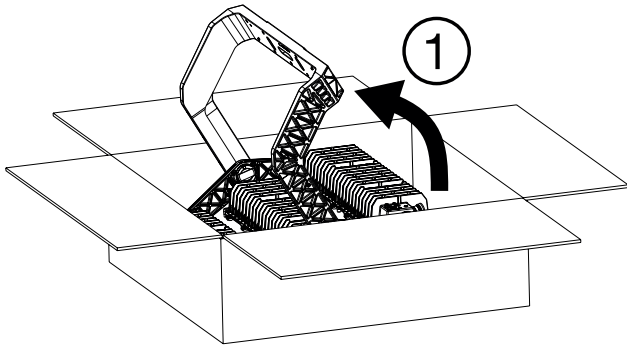

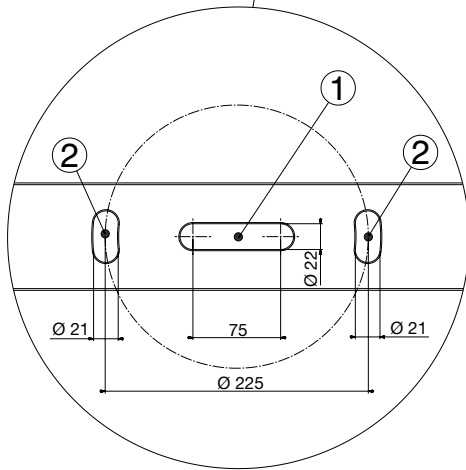
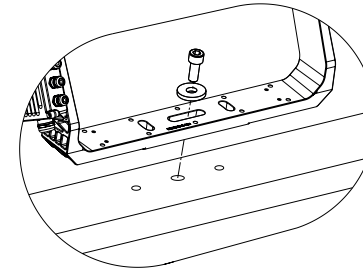
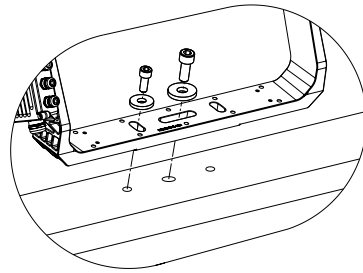
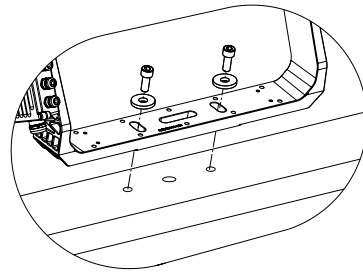
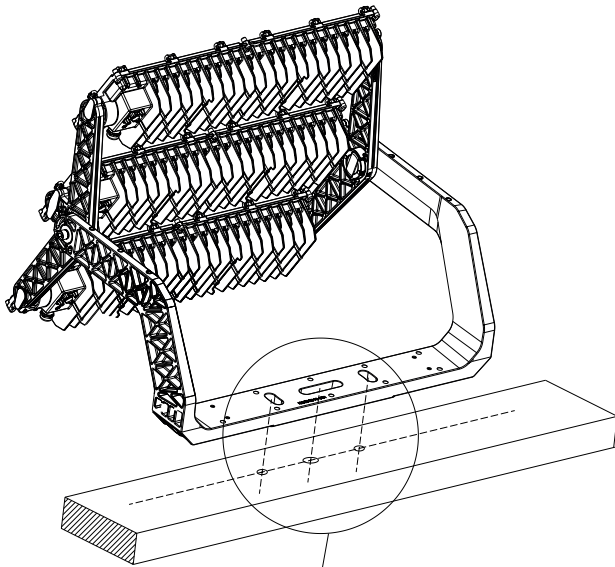

- | | | |
|---|--|---------|
| ① | | M20 |
| | | DIN9021 |
| ② | | M16 |
| | | DIN9021 |

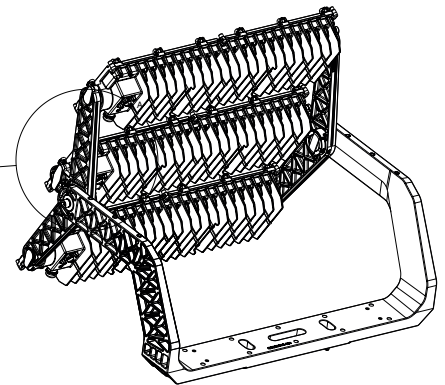
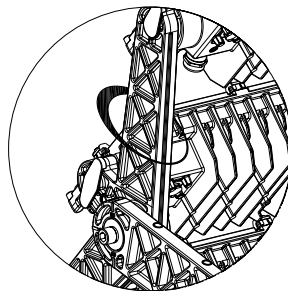
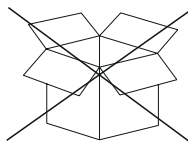

IT Per installazioni superiori a 3m assicurare il proiettore sulla spalla metallica con catena (es. GWS6922) o cavo di acciaio. -

AR راطال دن ع ذالوف لباك وا (GWS6922 قباسرل ال يدومل) قلع لسب فاشرفال نيم اكب بق ، راتم 3 زواجتي عافترا على ع بيكورتل

BE Для установки вышэй за 3 м замаўце праэктар на раме з дапамогай ланцуга (раней GWS6922) або сталёвага кабеля. - **BG** За монтаж на височина, по-голяма от 3 метра, закрепете прожектора при рамката с верига (напр. GWS6922) или стоманен кабел. - **CS** Při instalaci do výšky větší než 3 metry zajistěte světlomet k rámečku pomocí řetězu (ex GWS6922) nebo ocelového lanka. - **DA** For installationer på over 3m skal projektøren fastgøres på metalansatsen med kæde (eks. GWS6922) eller stål kabel. - **DE** Bei Installationen über 3m den Scheinwerfer auf der Metallschulter mit Kette (Bsp. GWS6922) oder Stahlseil sichern. - **EL** Για εγκαταστάσεις άνω των 3 μέτρων στερεώστε τον προβολέα στη μεταλλική βάση με αλυσίδα (π.χ. GWS6922) ή σιματόσχοινο. - **EN** For installation higher than 3m secure the floodlight at the frame with chain (ex GWS6922) or steel cable. - **ES** Para instalaciones superiores a 3m, asegure el proyector en el soporte metálico con cadena (por ej.: GWS6922) o cable de acero. - **ET** Paigaldamiseks kõrgemale kui 3 m kinnitage prožektor raami külge keti (nt GWS6922) või teraskaabli abil. - **FI** 3 metriä ylittävälle asennuksille valonheittimen kiinnitys metallitukeen on varmistettava ketjulla (esim. GWS6922) tai teräskaapelilla. - **FR** Pour les installations de plus de 3 m, fixer le projecteur sur l'épaulement métallique avec une chaîne (p. ex. GWS6922) ou un câble en acier. - **GA** Má táthar chun é a shuiteáil níos airde ná 3m, daingnigh an tuilsolas ag an bhfráma le slabhra (m. sh. GWS6922) nó le cábla cruach. - **HR** Kod postavljanja na visini većoj od 3 m učvrstite reflektor na metalnom okviru pomoću lanca (npr. GWS6922) ili čeličnog kabela. - **HU** 3 méteren túllépő telepítések esetén biztosítsa ki a fényvetőt a fémtartón láncsal (pl. GWS6922) vagy acélkábelrel. - **KK** 3 метрден жоғары биіктікке орнатылатын болса, прожекторды жақтауға шынжыр (ex GWS6922) немесе болат арқанның көмегімен бекітіңіз. - **LT** Jei norite įrengti prožektorių aukščiau nei 3 m, pritvirtinkite jį prie rėmo su grandine (pvz. GWS6922) arba plieniniu kabeliu. - **LV** Uzstādot augstumā, kas lielāks par 3 m, nostipriniet prožektora gaismu, pie rāmja pievienojot ķēdi (piem., GWS6922) vai tērauda trosi. - **MT** Għal installazzjoni f'għoli ta' aktar minn 3 m, waħħal il-floodlight mill-frejġ m' b'katina (ex GWS6922) jew b'kejbil tal-azzar. - **NL** Voor installaties hoger dan 3m moet het spreidlicht op de metalen houder met ketting (es. GWS6922) of stalen kabel bevestigd worden. - **NO** For installasjoner over 3 m må projektoren sikres på metallanslag med kjede (f.eks. GWS6922) eller stål kabel. - **PL** W instalacjach powyżej 3 m przymocować projektor na metalowym ramieniu łańcuchem (np. GWS6922) lub stalowym kablem. - **PT** Para instalaçãoes acima de 3 m, prenda o projetor no suporte metálico com corrente (p. ex., GWS6922) ou cabo de aço. - **RO** Pentru instalarea la o înălțime mai mare de 3m asigurați proiectorul de cadru cu un lanț (ex GWS6922) sau un cablu de oțel. - **RU** При установке выше 3м закрепите прожектор на металлическом кронштейне цепью (например, GWS6922) или стальным тросом. - **SK** Při inštalácii do výšky väčšej než 3 metre zaistite svetlomet k rámečku pomocou reťaze (ex GWS6922) alebo ocelového lanka. - **SL** Za montažo višje 3 m projektor pritrdite na kovinsko konzolo z verigo (npr. GWS6922) ali jekleno vrvjo. - **SV** För installationer högre än 3 meter ska strålkastarens metallram säkras med kedja (t.ex. GWS6922) eller stålvajer. - **TR** 3m'den daha yüksek bir konuma montaj için, projektörü çerçeveye zincir (örn. GWS6922) ya da çelik kablo ile sabitleyin. - **ZH** 如果在 3m 以上高度安装, 则应使用链条 (ex GWS6922) 或钢缆, 将泛光灯固定于车架。

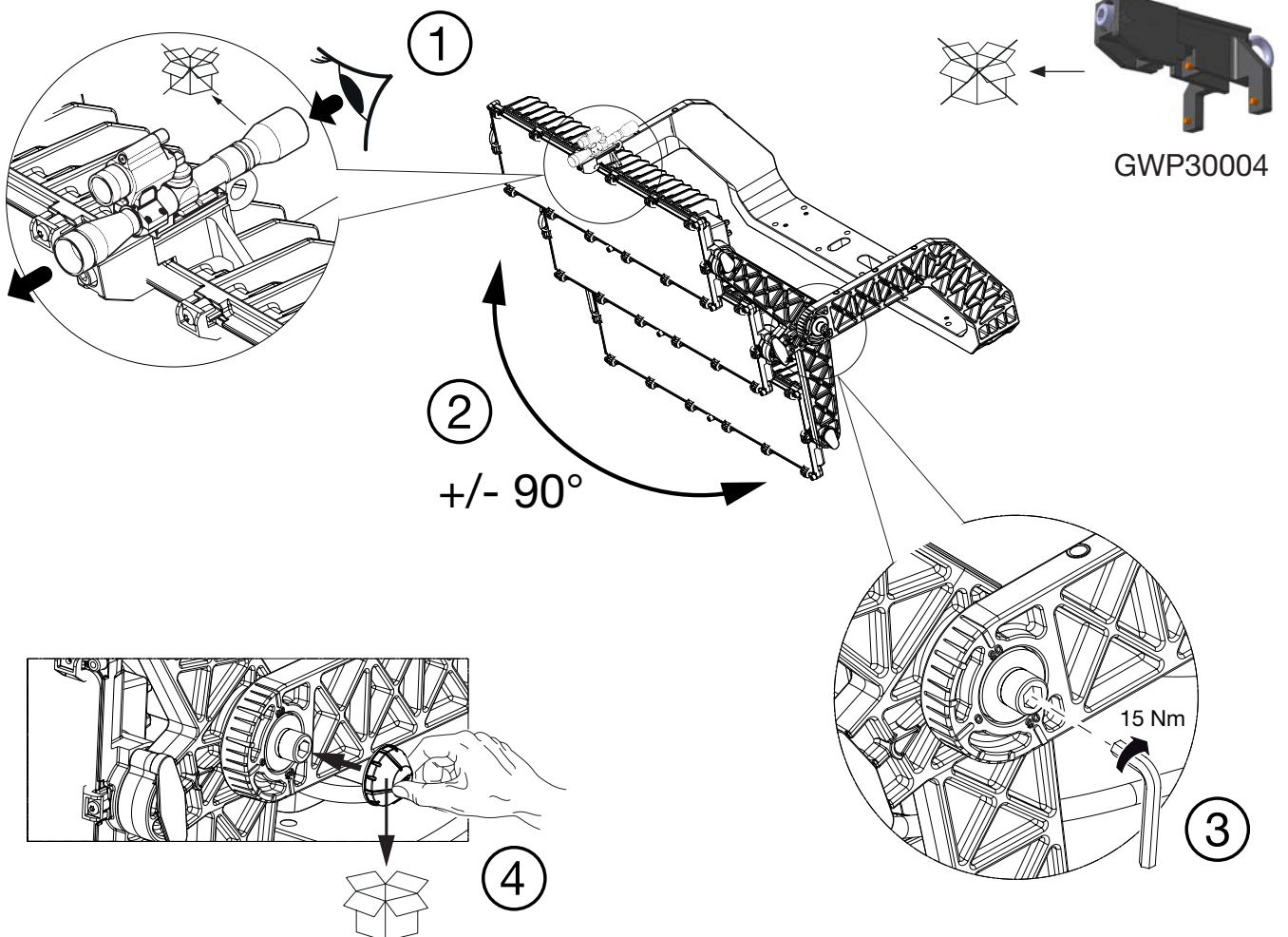
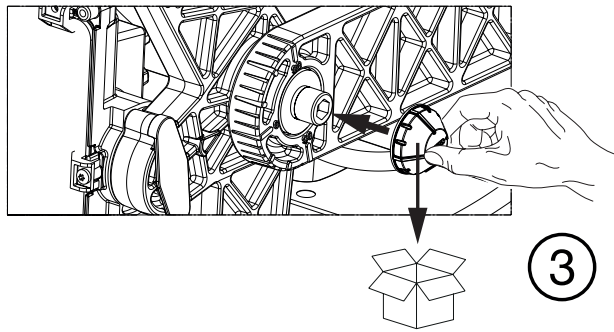
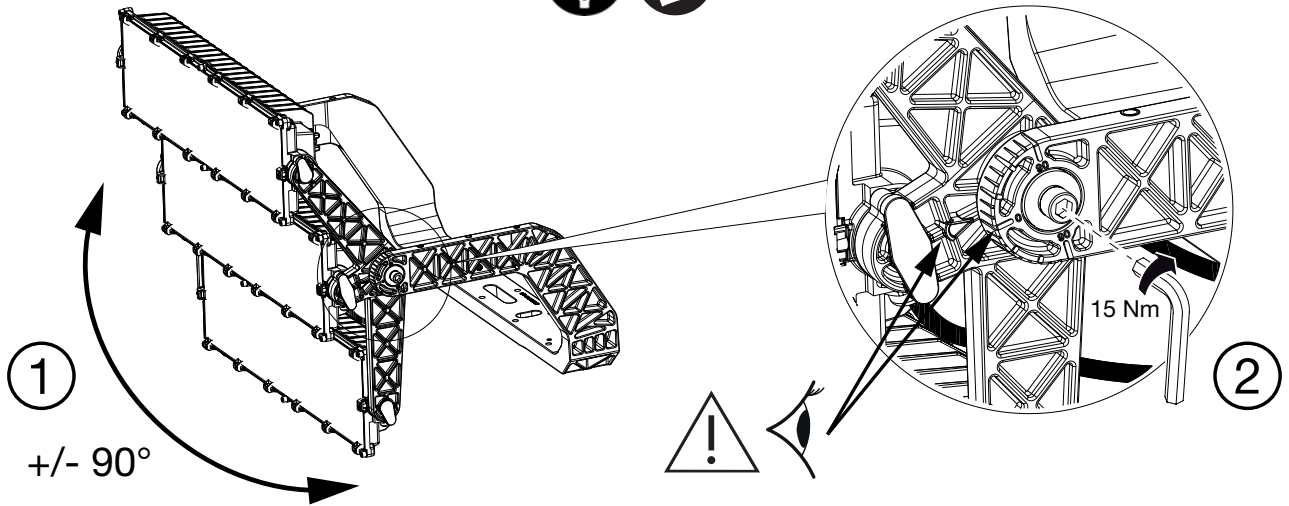

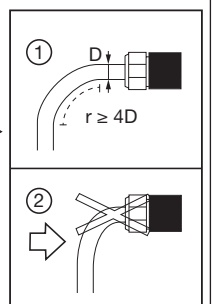
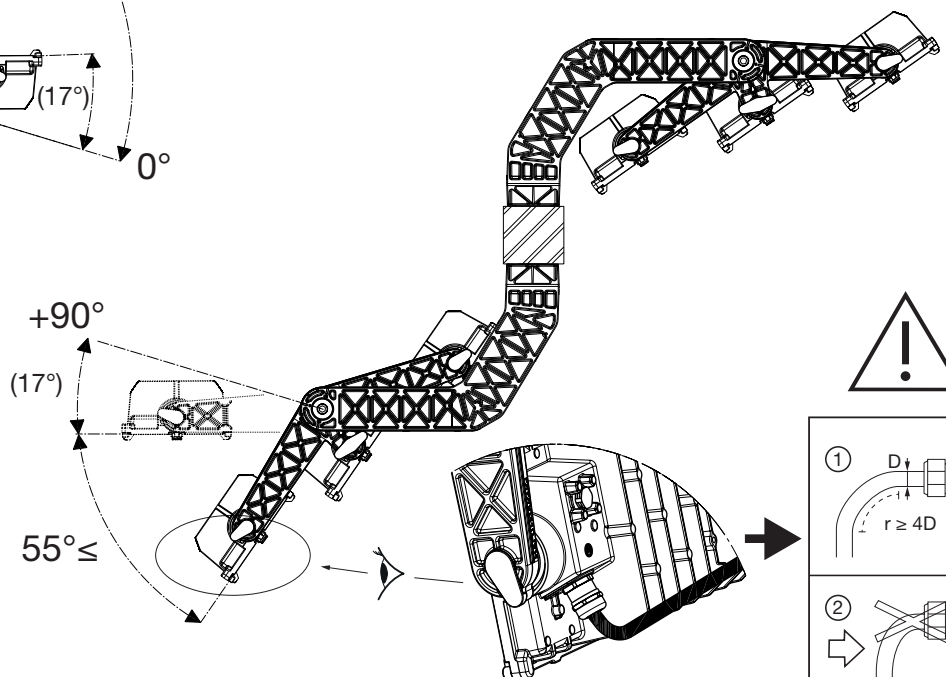
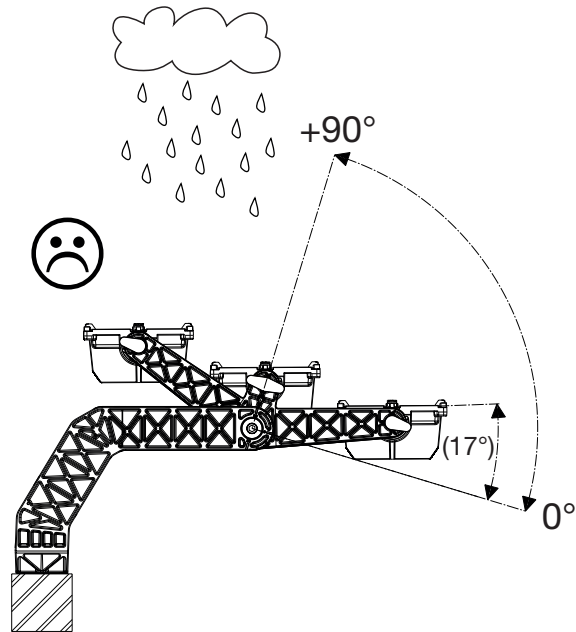
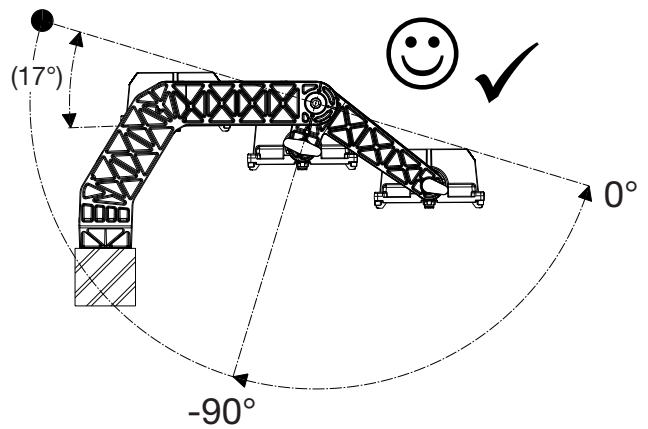
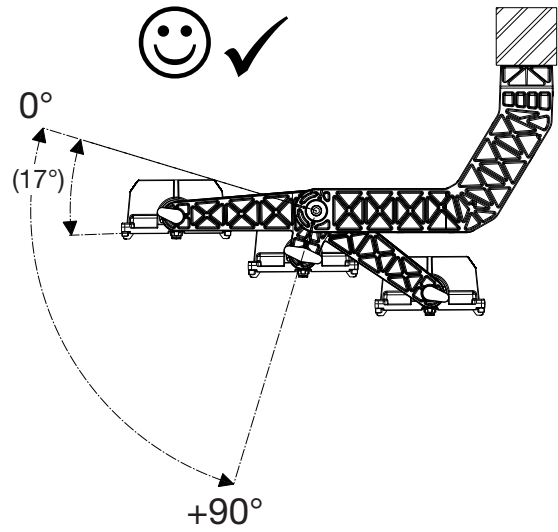
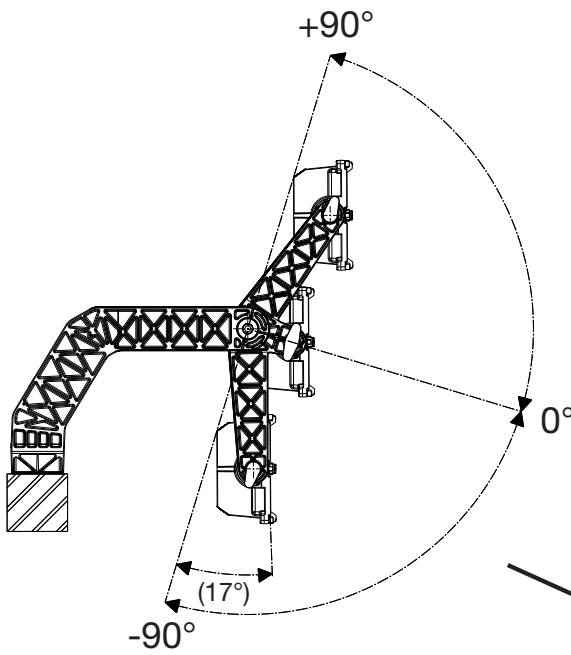

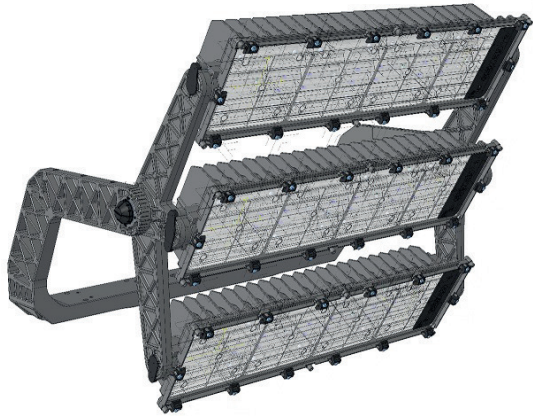

A1

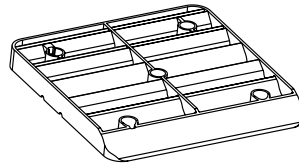

A2

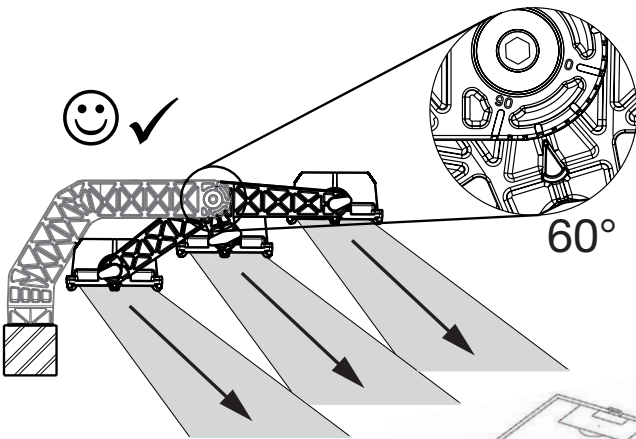
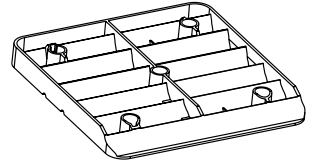

60°

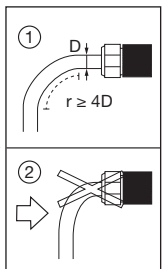
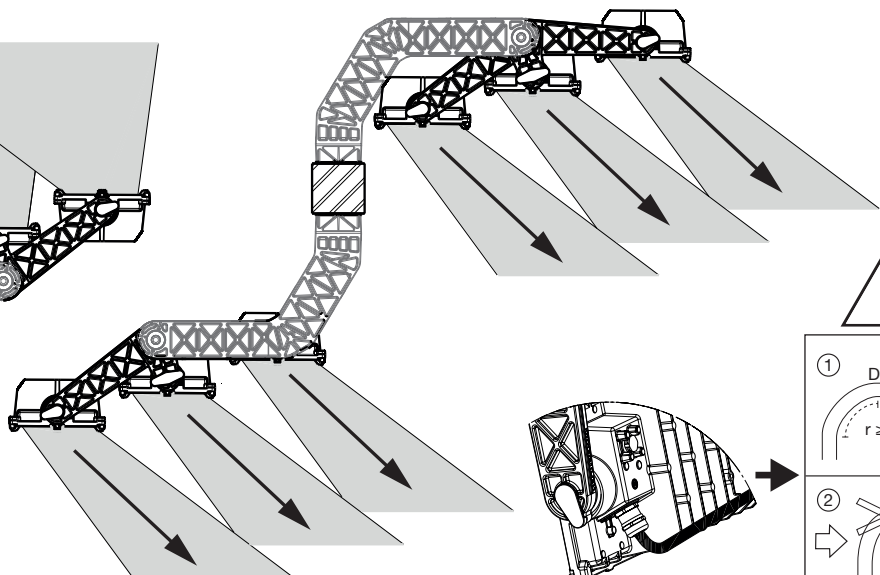
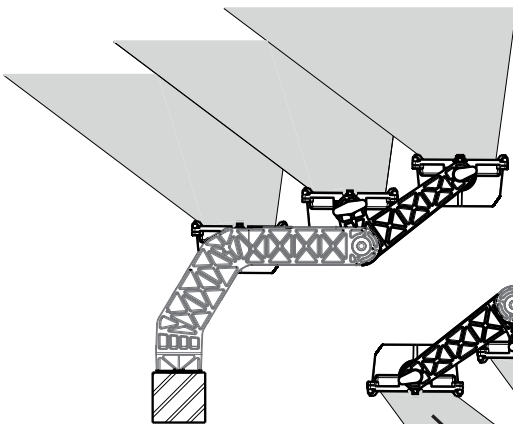
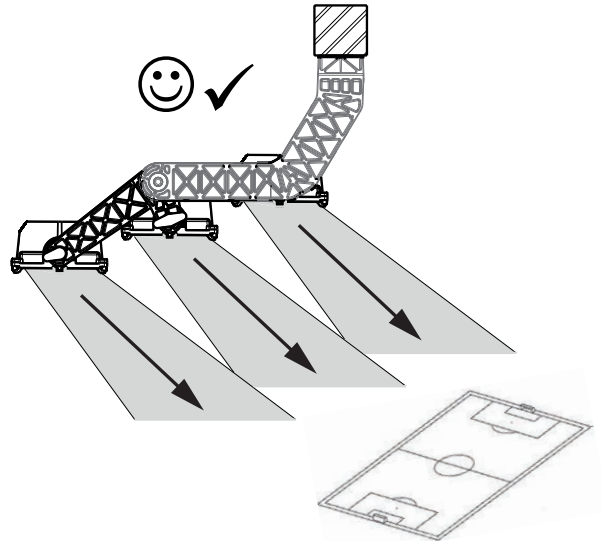

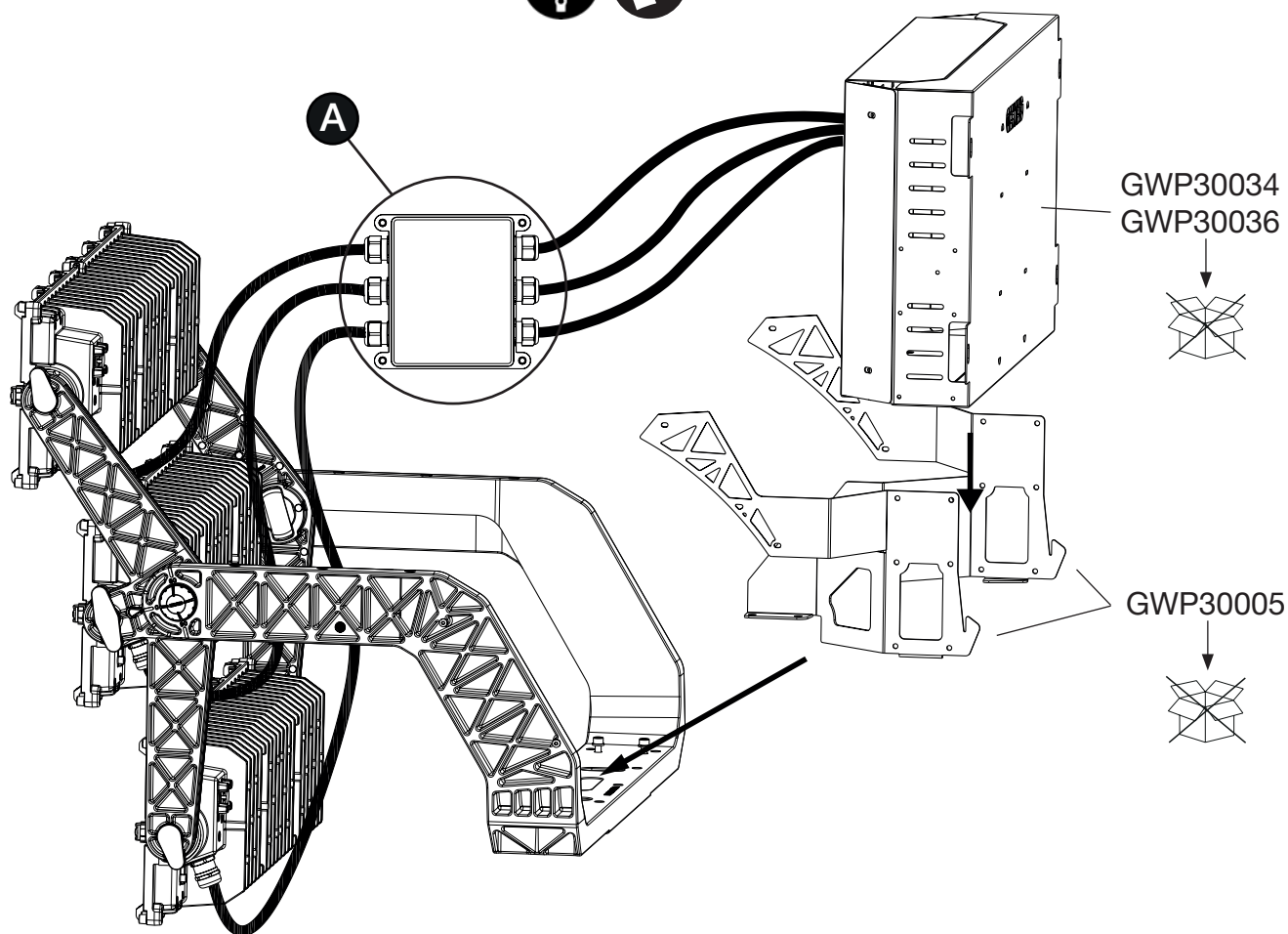

A GWP30037 →



DALI / 0-10V					
	=	L	=	+	
-	=	N	=	-	
⊕	=	⊕	=	⊕	
①	=	DA+	=	①	
②	=	DA-	=	②	

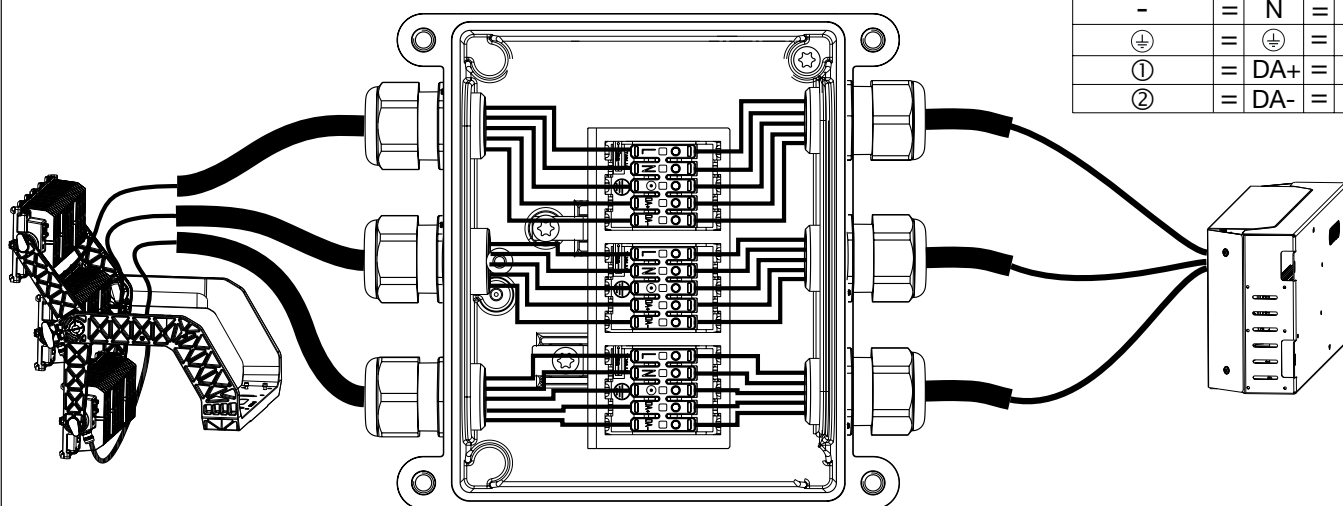

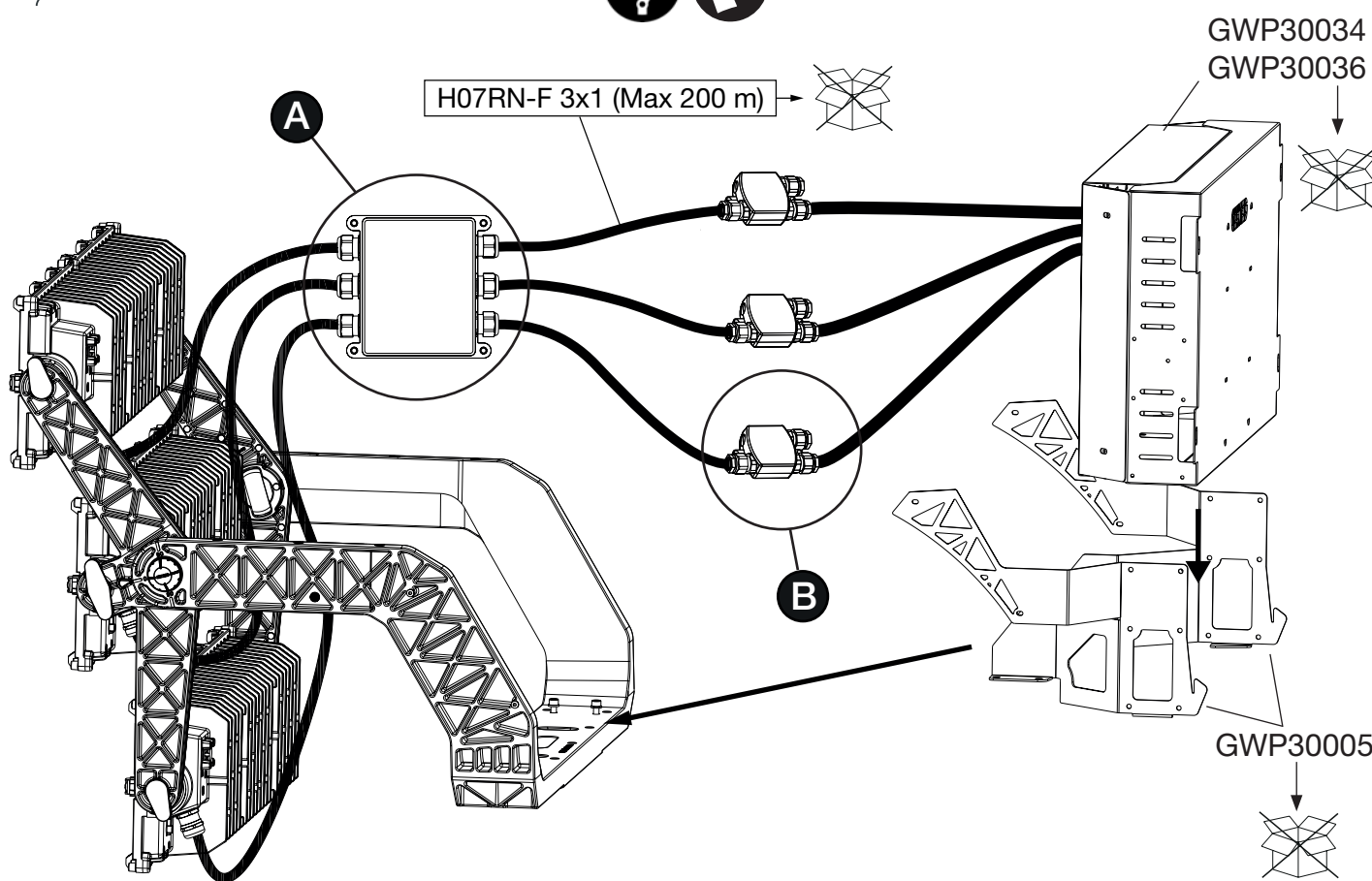

A GWP30037 →



DALI / 0-10V

+	= L	= +
-	= N	= -
⊕	= ⊕	= ⊕
①	= DA+	= ✕
②	= DA-	= ✕

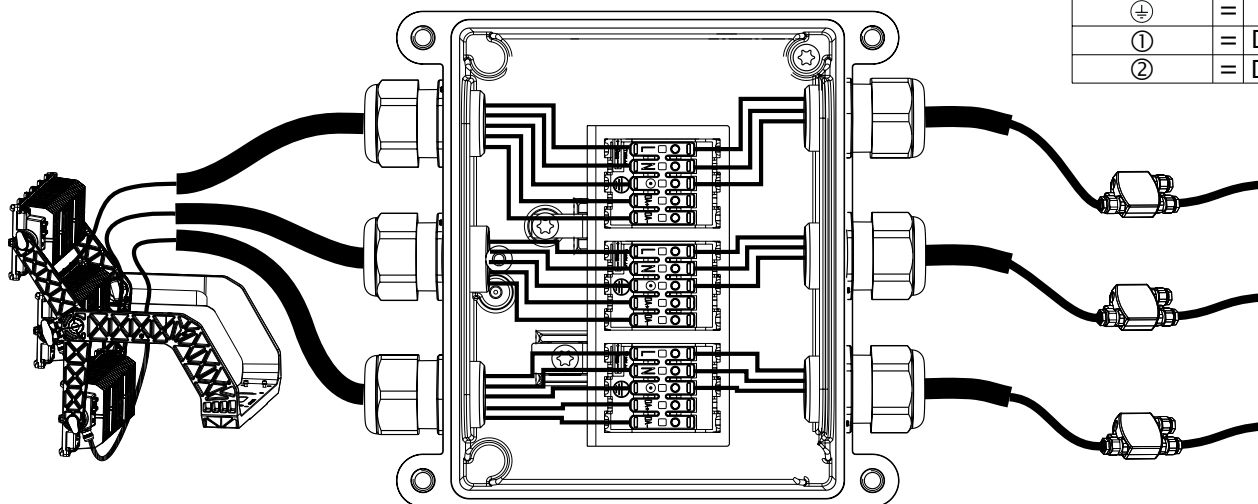



B GWP20113 →

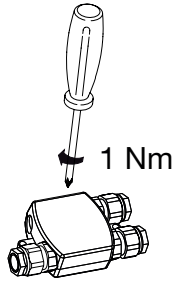

DALI / 0-10V	
L	= LED+
N	= LED-
	=
	= ①
	= ②

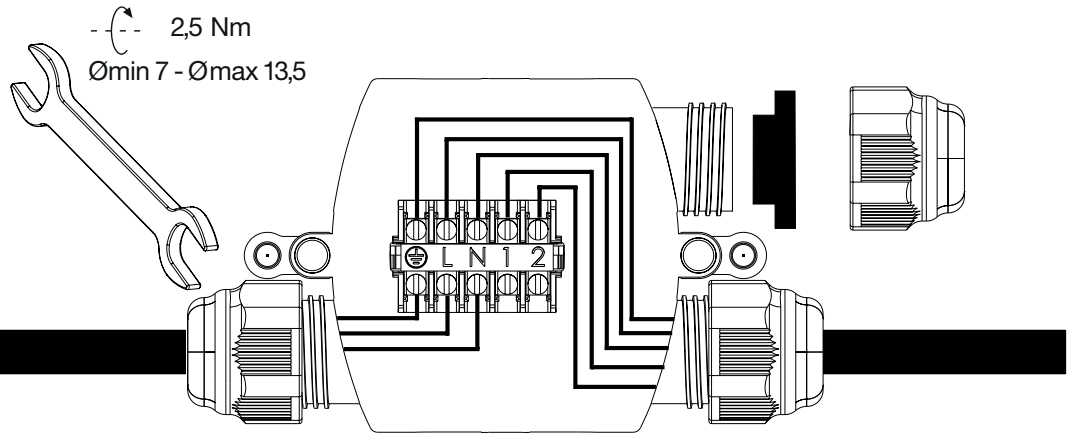

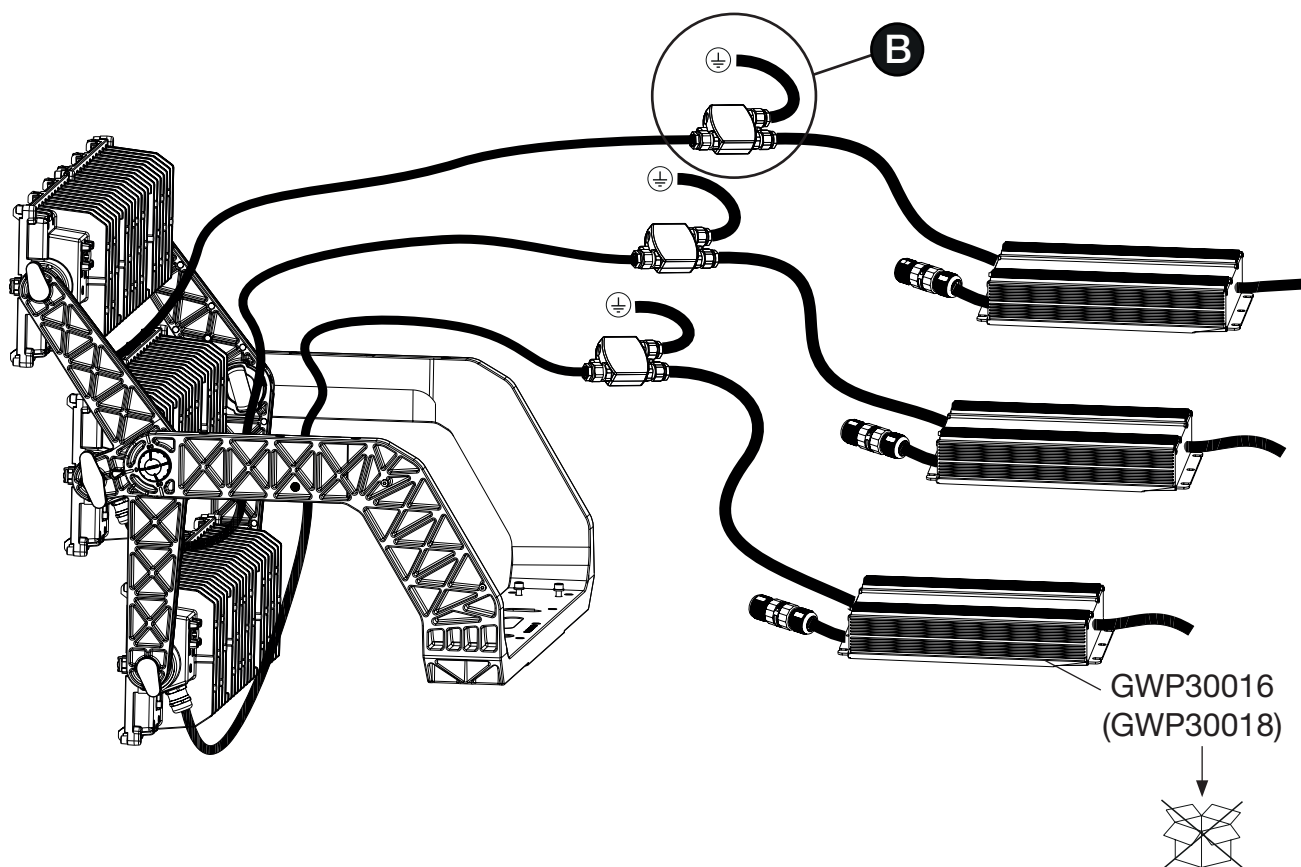

B GWP20113 →

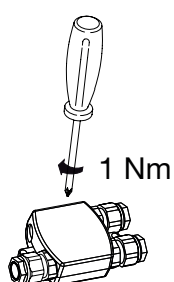

DALI / 0-10V		
L	=	LED+
N	=	LED-
⊕	=	⊕
①	=	⊗
②	=	⊗

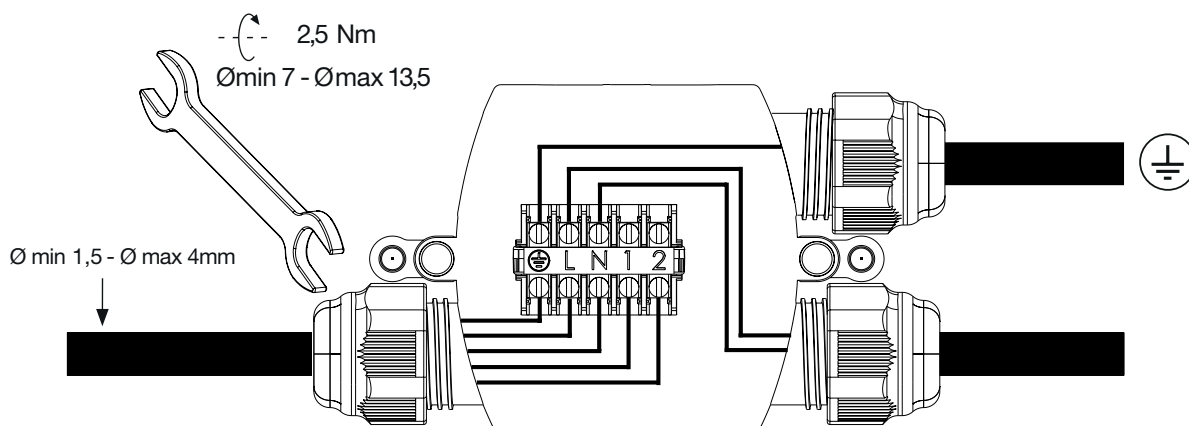

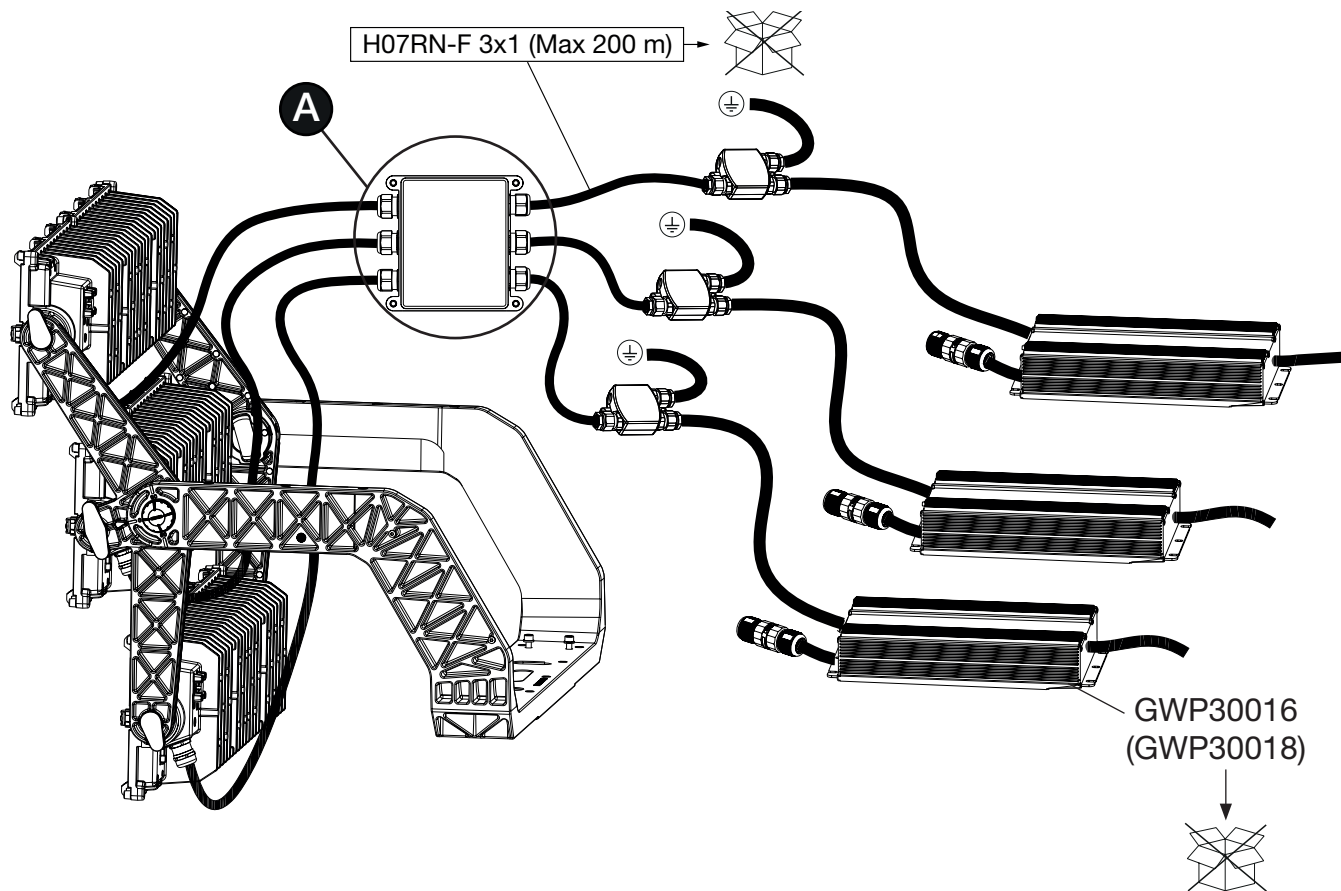

A GWP30037 →



DALI / 0-10V	
L	= LED+
N	= LED-
⊕	= ⊕
①	= ⊕
②	= ⊕

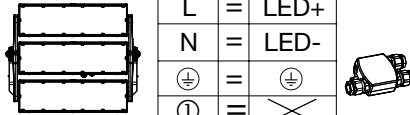
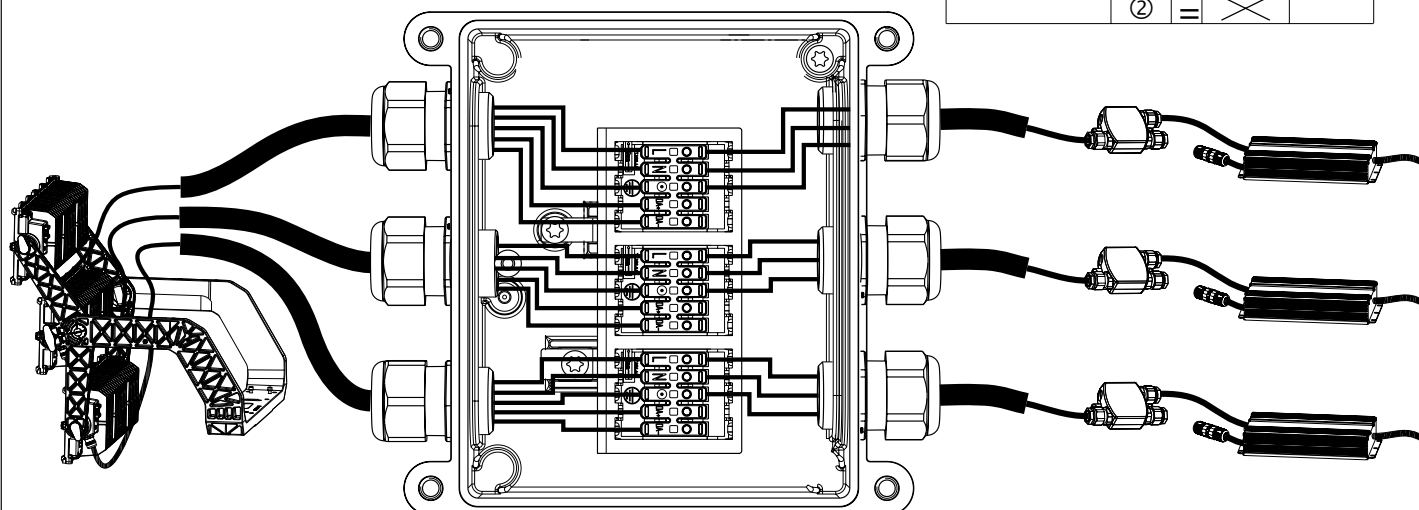

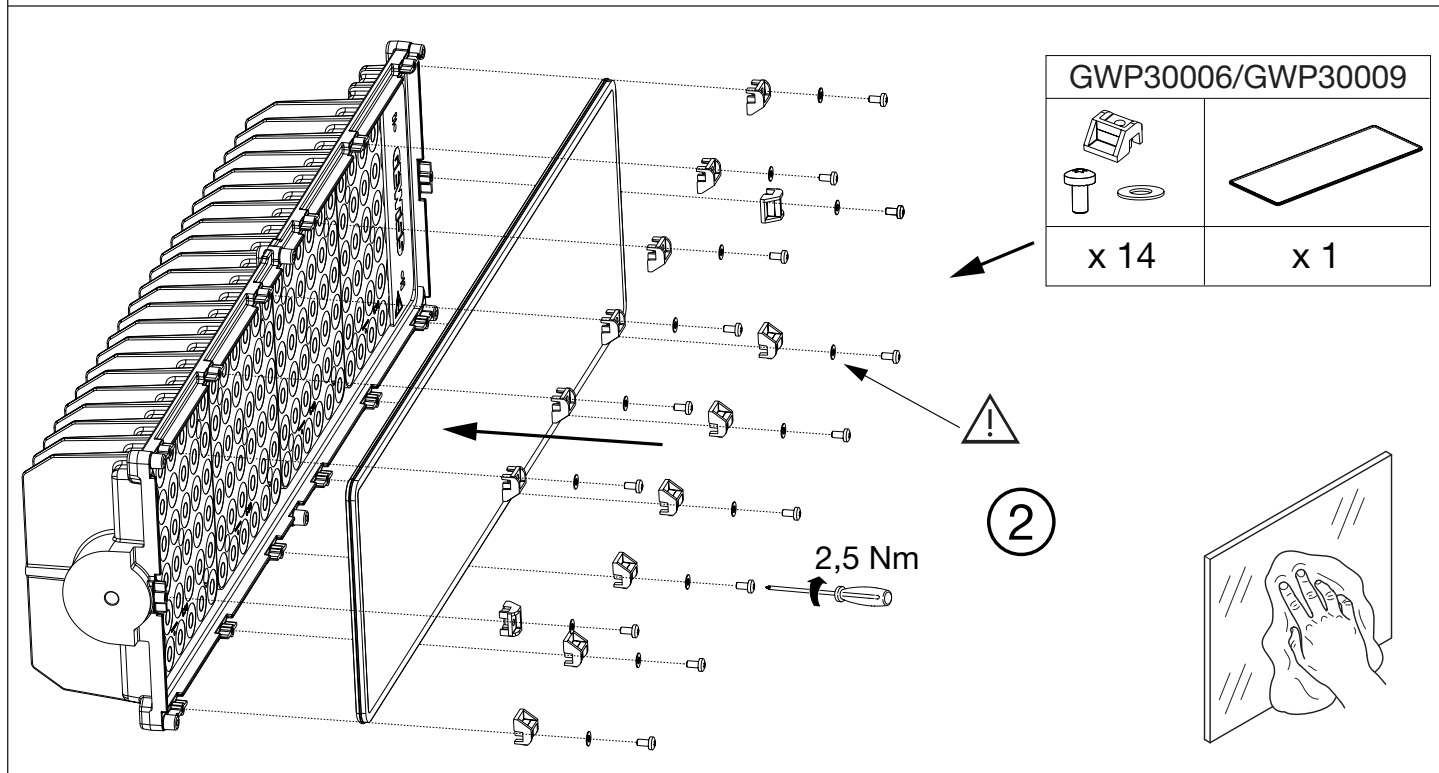
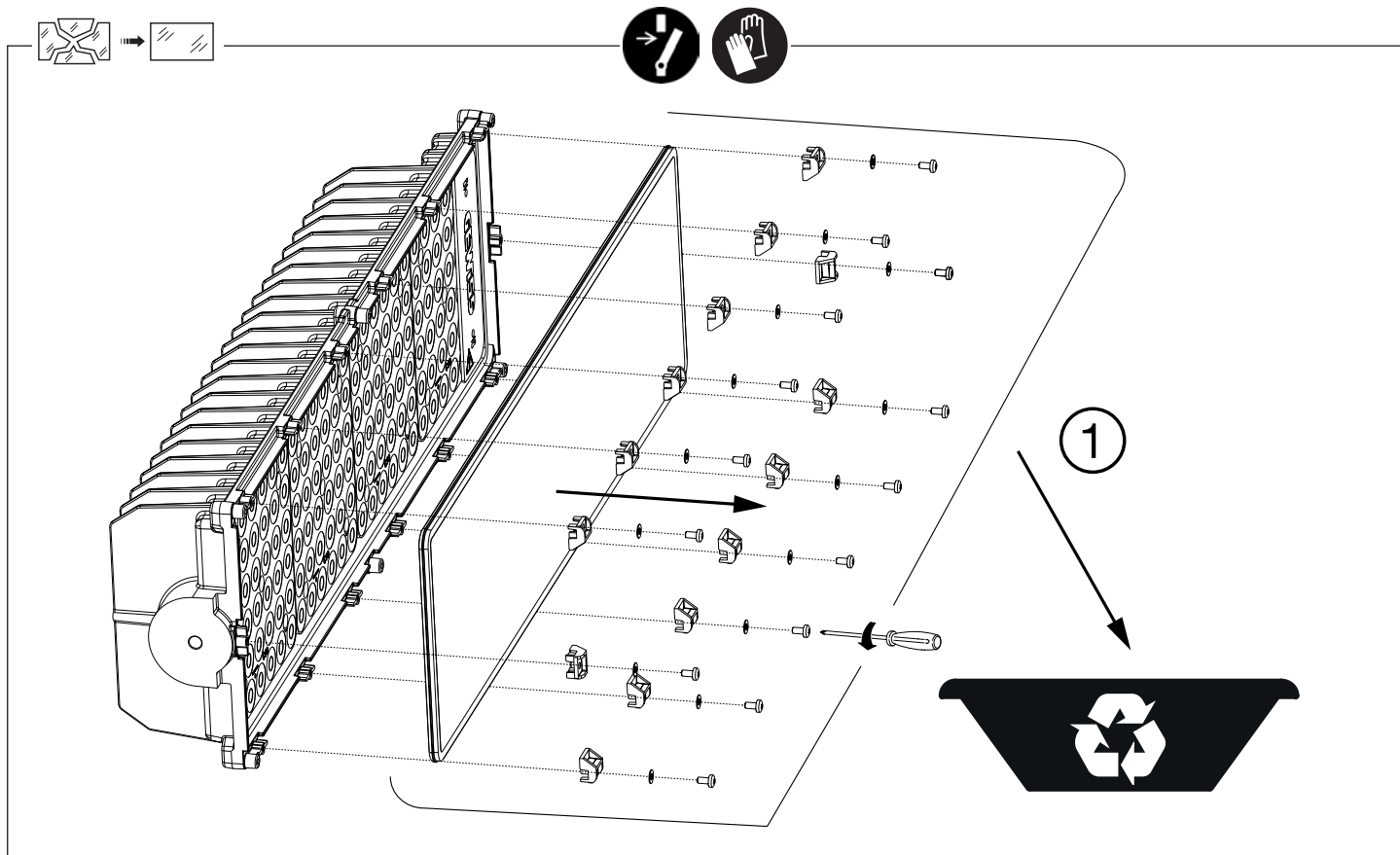
	OPTICS			
	A1	A2	S1	C1
GWP30006			✓	✓
GWP30009	✓	✓		



Standard Picatinny



GWP30004

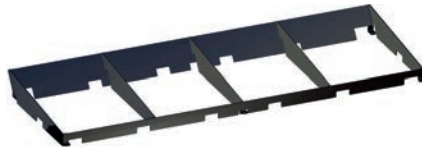

GWP30003

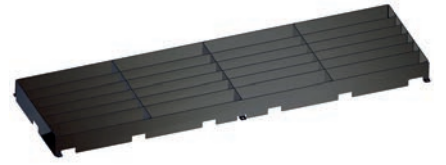

GWP30002

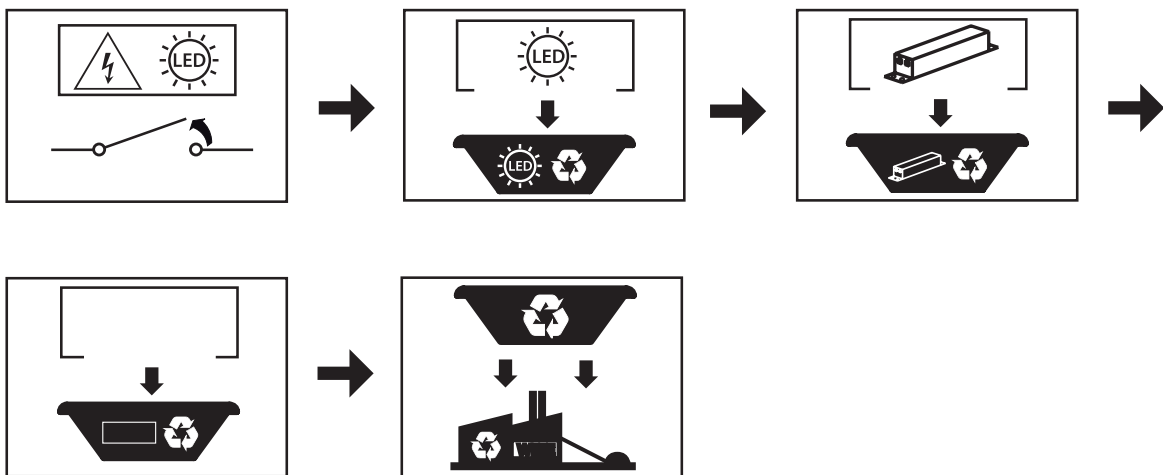
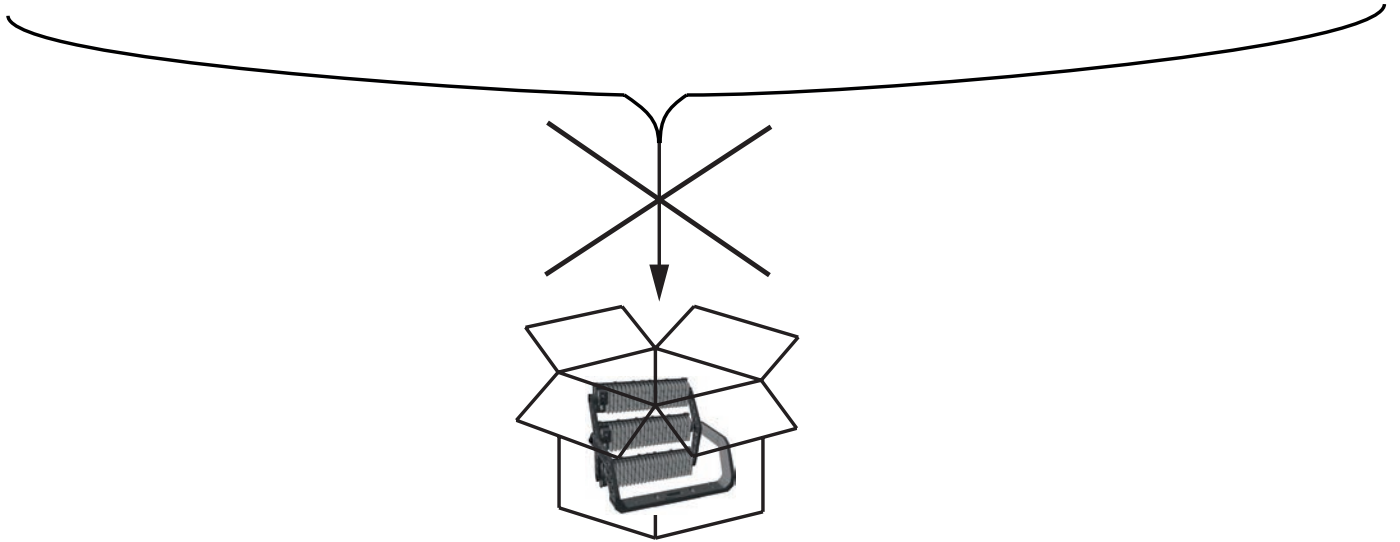

IT Si specifica che ai fini della protezione degli apparecchi di illuminazione nei confronti delle sovratensioni potrebbe essere necessario installare dei dispositivi di protezione esterni (es. SPD, scaricatori di sovratensione) le cui caratteristiche devono essere coordinate con i valori di tenuta ai surge degli apparecchi di illuminazione stessa. Per la valutazione dei rischi di sovratensione e per la scelta dei relativi dispositivi di protezione esterni fare riferimento alle norme in vigore nel Paese di installazione. -

اقتباساتنا بجوي (SPD) اراضتخا اهدلدا راشئوي يىابىرطقدا دهجلدا يف يىافىقلى اعفستارال ان يف يىامحل ادهجلا لثم) فوي قراخ فوامح قدهج ابيقرت ويرورضنلما نم نوكي ذق ،ديازلل يىابىرطقدا دهجلدا نم فاضاللا قدهج ا فوامح لاج نم دنا مئلا راشئ اسفن فاضاللا قدهج اخراج نصراخل يىابىرطقدا دهجلل يىافىقلى اعفستارال فواقم موي عم اصيواصخ

AR بيقرتلا موي مئتي يذلا دلبللا يف اهب لومئلا ريياعملا عراج ،نمسانملا يىابىرطقدا قدهج ابيقرتلا قدهج ا يىابىرطقدا دهجلدا رطاخم ميقيقتل

BE Удкладняцца, што для абароны асвятляльных прыбораў ад перанавругі можа запатрабавацца ўстаноўка знадворных ахоўных прыбораў (на прыклад, прыбораў абароны ад імпульсных знадворных прыбораў абароны, звярнуцца да стандартаў, што дзейнічаюць у краіне ўсталяўкі. -

BG Уточнява се, че за целите на защитата на устројтава за осветление от свръхнапрежение може да е необходимо да се инсталират външни защитни устројтава (напр. SPD, устројтава за защита от свръхнапрежение), чиито характеристики трябва да съответстват на стойностите на устойчивостта на устројтава от свръхнапрежение на самите . За да се оценят рисковете от свръхнапрежение и да се избера съответните външни предпазни устројтава, се препраща към стандартите, действащи в страната на инсталиране. -

CS Je stanoveno, že pro účely ochrany osvětlovacích zařízení před přepětím může být nutné instalovat externí ochranná zařízení (např. SPD, přepětová ochranná zařízení), jejichž vlastnosti musí odpovídat hodnotám přeřetové odolnosti samotných osvětlovacích zařízení. Pro posouzení rizik přepětí a výběr příslušných vnějších ochranných zařízení se řídte normami platnými v zemi instalace. -

DA Det specificeres, at det for at beskytte belygningsanordningerne mod overspænding kan være nødvendigt at installere eksterne beskyttelsesanordninger (f.eks. SPD, overspændingsbeskyttelse), hvis egenskaber skal være i overensstemmelse med selve belygningsanordningernes værdier for overspændingsmodstand. For at vurdere risikoen for overspænding og vælge de tilhørende eksterne beskyttelsesanordninger henvises til de gældende standarder i installationslandet. -

DE Es ist zu beachten, dass zum Schutz der Beleuchtungsgeräte vor Überspannung ggf. externe Schutzvorrichtungen (wie etwa ÜSA, Überspannungsableiter) installiert werden müssen, deren Eigenschaften den Überspannungsfestigkeitswerten der Beleuchtungsgeräte selbst entsprechen müssen. Zur Beurteilung der Überspannungsrisiken und zur Auswahl der entsprechenden externen Schutzgeräten sind die im Installationsland geltenden Normen heranzuziehen. -

EL Διευκρινίζεται ότι για την προστασία των συσκευών φωτισμού από την υπέρταση μπορεί να είναι απαραίτητη η εγκατάσταση εξωτερικών συσκευών προστασίας (π.χ. συσκευές προστασίας από υπερβολική τάση), τα χαρακτηριστικά των οποίων πρέπει να αντιστοιχούν στα αντίστοιχα σε υπέρτασης των ίδιων των συσκευών φωτισμού. Για να εκτιμήσετε τους κινδύνους υπέρτασης και να επιλέξετε τις σχετικές εξωτερικές συσκευές προστασίας, ανατρέξτε στα πρότυπα που ισχύουν στη χώρα εγκατάστασης. -

EN It is specified that for the purpose of protecting the lighting devices from over-voltage, it may be necessary to install external protection devices (e.g. SPD, surge protective devices), the features of which must comply with the surge resistance values of the lighting devices themselves. To assess the risks of over-voltage and select the related external protection devices, refer to the standards in force in the country of installation. -

ES Se especifica que, para proteger los aparatos de iluminación de la sobretensión, puede ser necesario instalar aparatos de protección externos (por ejemplo, SPD, aparatos de protección contra sobretensiones), cuyas características deben cumplir los valores de resistencia a las sobretensiones de los propios aparatos de iluminación. Para evaluar los riesgos de sobretensión y seleccionar los aparatos de protección externos correspondientes, refiérase a las normas vigentes en el país de instalación. -

ET On määratud, et valgustusseadmete ülepinge eest kaitsmise otstarbel võib olla tarvis paigaldada väliseid kaitseseadmeid (nt liigpingekaitseseadmeid), mille omadused peavad vastama valgustusseadmete enesete liigpingekiindluse väärtustele. Ülepinge ohtude hindamiseks ja nendega seotud väliste kaitseseadmete valimiseks vaadake paigaldusriigis kehtivaid standardeid. -

FI Ilmoitetaan, että valaistuslaitteiden suojaamiseksi ylijännitteeltä voi olla tarpeen asentaa ulkoisia suojalaitteita (esim. SPD, ylijännitesuoja laitteet), joiden ominaisuuksien on vastattava itse valaistuslaitteiden ylijännitteen kestävyyttä koskevia arvoja. Ylijännitteen vaarojen arvioimista ja vastaavan ulkoisen suojalaitteen valitsemista varten, noudata asennusmaassa voimassa olevia standardeja -

FR Dans le but de protéger les appareils d'éclairage contre une surtension, il est précisé que l'installation d'appareils de protection extérieurs (par ex. des SPD, dispositifs de protection contre les surtensions), dont les caractéristiques sont conformes aux valeurs de résistance aux surtensions des appareils d'éclairage, peut s'avérer nécessaire. Pour évaluer les risques de surtension et sélectionner les appareils de protection extérieurs correspondants, consulter les normes en vigueur dans le pays d'installation. -

GA D'fhonn na gairis soilsihe a chosaint ar róivoltas, sonraítear go bhféadfaidh gá le bheith le feistí cosanta seachtaracha a shuiteáil (e.g. FCBanna, feistí cosanta ar bhorrhadh), ag a bhfuil gnéithe nach mór dóibh cloí leis na luachanna fritiáochtá bhortha de na gairis soilsihe féin. Chun na rioscaí a bhaineann le róivoltas a mheasúnú agus na feistí cosanta seachtaracha gaolmhara a roghnú, féach ar na caighdeán atá i bhfeidhm sa tír inar suiteáladh iad. -

HR Naznačeno je da radi zaštite uređaja za osvjjetljenje od prenapona može biti potrebno ugraditi vanjske zaštitne uređaje (npr. SPD, ograničivače prenapona), čije značajke moraju odgovarati vrijednostima otpornosti samih uređaja za osvjjetljenje na prenapon. Kako biste procijenili rizik od prenapona i odabrali odgovarajući vanjske zaštitne uređaje, proučite norme koje su na snazi u zemlji ugradnje. -

HU Az előírás szerint a világítóbereendezések túlfeszültségtől való védelme érdekében szükséges lehet külső védőberendezések (pl. SPD, túlfeszültség-védő eszközök) beszerelése, amelyek jellemzőinek meg kell felelniük a világítóbereendezések túlfeszültség-ellenállási értékeinek. A túlfeszültségtől való védelem érdekében szükséges a kapcsolódó külső védőeszközök kiválasztásához vegye figyelembe a telepítés országában érvényben lévő szabványokat. -

KK Жақықтандыру құрылғыларының асқын кернеуден қорғау үшін сыртқы қорғаныс құрылғыларын (мысалы, SPD, асқын кернеуден қорғау құрылғылары) орнату қажет болуы мүмкін, олардың сипаттамалары жақықтандыру құрылғыларының асқын кернеуге төзімділік мәндеріне сәйкес келуі керек. Шамадан тыс жүктемеден төнетін қауіптерді бағалау және тиісті сыртқы қауіпсіздік құрылғыларын таңдау үшін орнатылатын елде қолданылатын стандарттарды қараңыз. -

LT Norint apšviétimo įrenginius apsaugoti nuo viršįtampių, svarbu naudoti papildomas apsaugos priemonės, pavyzdžiui, apsaugos nuo viršįtampių įtaisus (pvz., apsaugos nuo įtampos šuolių įrenginiai). Šių įtaisų savybės turi atitikti pačių apšviétimo įrenginių atsparumo viršįtampiams vertes. Norint įvertinti viršįtampio rizikas ir pasirinkti susijusius išorinius apsaugos įrenginius, reikia vadovautis šalyje, kurioje bus montuojama įranga, galiojanciais standartais. -

LV Noteikts, ka apgaismes ierīcu aizsardzībai no pārsprieguma var būt nepieciešams uzstādīt ārējās aizsargierīces (piemēram, SPD, pārsprieguma aizsargierīces), kuru īpašībām jāatbilst apgaismes ierīču pārsprieguma pretestības vērtībām. Lai novērtētu pārsprieguma risku un izvēlētos saistītās ārējās aizsardzības ierīces, skatiet uzstādīšanas valstī spēkā esošos standartus. -

MT Huwa speċifikat li għall-finijiet tal-protezzjoni tal-apparat tad-dawl minn vultagħ żejjed, jista' jkun neċessarju li tinstalla apparati ta' protezzjoni esterna (eż. apparati li jiproteġu kontra tluġh f'daqqa tal-kurrent (SPD)), li l-karatteristiċi tagħhom iridu jikkonformaw mal-valuri tar-reżistenza tat-tluġh f'daqqa tal-apparati tad-dawl infushom. Sabieb tinalvuta l-riskji ta' vultagħ żejjed u tagħzel l-apparati ta' protezzjoni esterna -

NL Hierbij wordt gespecificeerd dat het voor het beschermen van de verlichtingsapparaten tegen overspanning nodig kan zijn om externe beveiligingen te installeren (bijv. SPD, overspanningsbeveiligingsapparaten), waarvan de eigenschappen moeten voldoen aan de overspanningsweerstandswaarden van de verlichtingsapparaten zelf. Raadpleeg de normen die gelden in het land van installatie om de risico's van overspanning te beoordeelen en de bijbehorende externe beveiligingen te selecteren. -

NO Vi spesifiserer at for å beskytte belysningsproduktet mot overspenning vil det kunne være nødvendig å installere eksterne beskyttelsesinnretninger (f.eks. SPD, overspenningsvern), hvis egenskaper må være i samsvar med verdier e for svingningsmotstand for selve belysningsproduktet. For å vurdere faren for overspenning og velge de tilhørende eksterne beskyttelsesinnretningene henviser vi til de standardene som gjelder i installationslandet. -

PL Wskazuje się, że w celu ochrony urządzeń oświetleniowych przed przepięciami może być konieczne zainstalowanie zewnętrznych urządzeń zabezpieczających (np. SPD, ograniczników przepięć), których parametry odpowiadają wartościom odporności na przepięcia określonym dla urządzeń oświetleniowych. Aby ocenić ryzyko związane z przepięciami i dobrać odpowiednie zewnętrzne urządzenia zabezpieczające, należy zapoznać się z normami obowiązującymi w kraju instalacji. -

PT Especifica-se que, para proteger os aparelhos de iluminação contra sobretensões, pode ser necessária a instalação de dispositivos de proteção externa (por exemplo, SPD, dispositivos de proteção contra surtos), cujas características devem estar em conformidade com os valores de resistência a surtos dos próprios aparelhos de iluminação. Para avaliar os riscos de sobretensão e selecionar os dispositivos de proteção externa relacionados, consulte as normas em vigor no país de instalação. -

RO Este specificat că în scopul protejării dispozitivelor de iluminat de supratensiuni, poate fi necesară instalarea dispozitivelor de protecție externe (ex. SPD, descărcătoare de supratensiune), ale căror caracteristici trebuie să se conformeze valorilor de rezistență la supratensiune ale dispozitivelor de iluminat. Pentru a evalua riscurile de supratensiune și a selecta dispozitivele de protecție externe asociate, consultați standardele în vigoare în țara în care urmează să se instaleze. -

RU Уточняется, что для защиты осветительных приборов от перенапряжения может потребоваться установка внешних защитных устройств (например, УЗП, устройство защиты от перенапряжения), характеристики которых должны соответствовать значениям устойчивости к перенапряжению самих осветительных приборов. Для оценки риска перенапряжения и выбора соответствующих внешних защитных устройств обратиться к стандартам, действующим в стране установки. -

SK Špecifikujeme, že na účely ochrany osvetlovacích zariadení pred prepätím môže byť potrebné nainštalovať externé ochranné zariadenia (napr. SPD, prepät'ové ochranné zariadenia), ktorých vlastnosti musia zodpovedať hodnotám odolnosti samotných osvetlovacích zariadení pred prepätím. Pri posudzovaní rizík prepätia a výbere príslušného externého ochranného zariadenia si pozrite normy platné v krajine inštalácie. -

SL Določeno je, da je za zaščito svetlobnih naprav pred prenapetostjo morda treba namestiti zunanje zaščitne naprave (npr. prenapetostne zaščitne naprave), katerih lastnosti morajo biti skladne z vrednostmi prenapetostne odpornosti samih svetlobnih naprav. Za oceno tveganja prenapetosti in izbiro ustreznih zunanjih zaščitnih naprav upoštevajte standarde, ki veljajo v državi namestitve. -

SV För att skydda belysningsanordningarna från överspänning kan det vara nödvändigt att installera externa skyddsanordningar (t.ex. SPD, överspanningskydd), vars egenskaper måste överensstämma med belysningsanordningarnas värden avseende överspänningstålighet. För att bedöma riskerna med överspänning och välja lämpliga externa skyddsanordningar, se gällande standarder i installationslandet. -

TR Aydınlatma aygıtlarını aşırı gerilime karşı korumak için, özellikle aydınlatma aygıtlarının gerilim vurum direncine uygun olması gereken harici koruma cihazları (ör. alçak gerilim koruma şok cihazı) takmak gerekebilir. Gerilim yükselmesi risklerini değerlendirme ve ilgili harici koruma cihazlarını seçmek için, kurulumun yapıldığı ülkede yürürlükte olan standartlara başvurun. -

ZH 规定为保护灯光装置避免过电压，可能有必要安装外部保护装置（例如 SPD，即浪涌保护装置），该保护装置参数必须与灯光装置自身的浪涌电阻数值相匹配。要评估过电压风险并选择相应的外部保护装置，请参阅所在国现行相关标准。

Punto di contatto indicato in adempimento ai fini delle direttive e regolamenti UE applicabili:

Contact details according to the relevant European Directives and Regulations:

GEWISS S.p.A. Via D.Bosatelli, 1 IT-24069 Cenate Sotto (BG) Italy tel: +39 035 946 111 E-mail: qualitymarks@gewiss.com

According to applicable UK regulations, the company responsible for placing the goods in UK market is:

GEWISS UK LTD - Unity House, Compass Point Business Park, 9 Stocks Bridge Way, ST IVES

Cambridgeshire, PE27 5JL, United Kingdom tel: +44 1954 712757 E-mail: gewiss-uk@gewiss.com



+39 035 946 111

8:30 - 12:30 / 14:00 - 18:00

lunedì - venerdì / monday - friday



www.gewiss.com

