

# STADIUMPRO | 3

# GEWISS

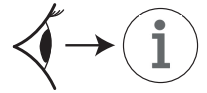
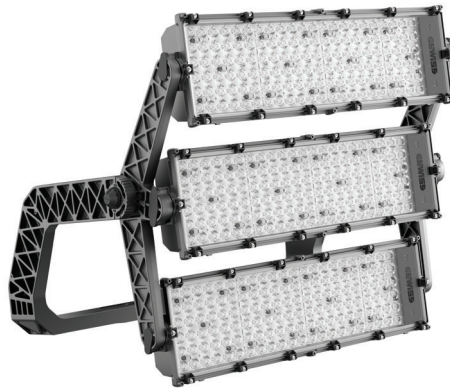

	Kg			I	Uout
	29 Kg	0,111 m <sup>2</sup>	0,362 m <sup>2</sup>	Max 1,2 A	Max 600 V <sup>~</sup>

t <sub>a</sub> +50°C	t <sub>a</sub> +35°C
	 ← Max = 200 m →
	 ← Max = 200 m →
	 ← Max = 200 m →

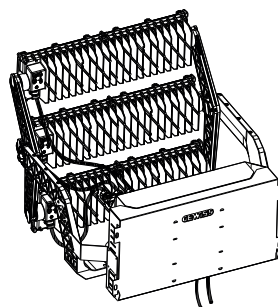
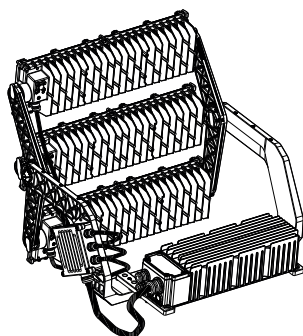

Ta	W	Lm
+25°C	100%	100%
+30°C	100%	100%
+35°C	100%	100%
+40°C	100%	100%
+45°C	95%	95%
+50°C	90%	90%

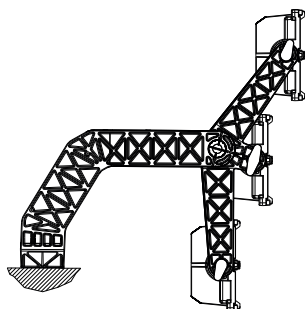

Ta	W	Lm
+25°C	100%	100%
+30°C	100%	100%
+35°C	100%	100%
+40°C	95%	95%
+45°C	92%	92%
+50°C	88%	88%

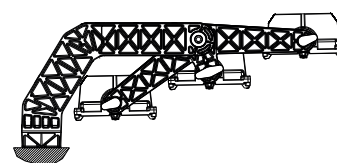

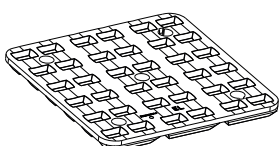
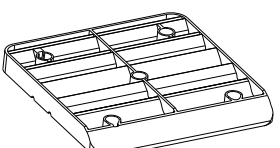
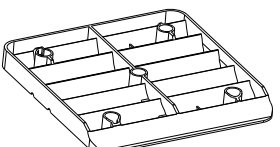
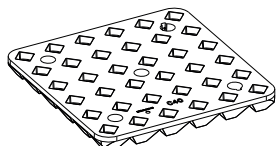
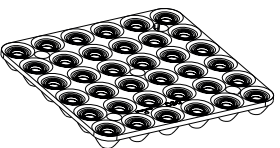
LED CCT		≤ 5700 K
Optics		RG1
	<b>S1</b> 20°x80°	20 m
	<b>A1</b> 45°	15 m
	<b>A2</b> 60°	14 m
	<b>C1</b> 40°	22 m
	<b>C2</b> 30°	23 m

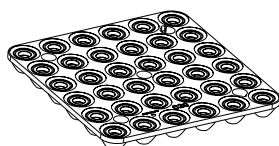
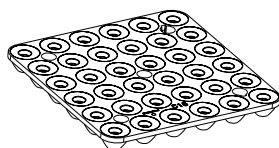
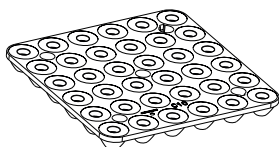
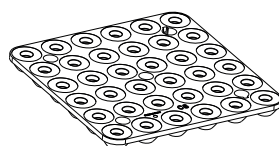
LED CCT		≤ 5700 K
Optics		RG1
	<b>C3</b> 20°	23 m
	<b>C4</b> 15°	24 m
	<b>C5</b> 10°	24 m
	<b>C6</b> 8°	23 m

	GWP3331AXXX	GWP3332AXXX	GWP3336AXXX
GWP30031 	1450W (400V: 1445W)	1460W (400V: 1455W)	1450W (400V: 1445W)
GWP30032 			
GWP30033 	1520W	1530W	1520W
GWP30035 	1500W	1530W	1500W
3 x GWP30015 	1500W	1520W	1500W
3 x GWP30017 	1500W	1520W	1500W

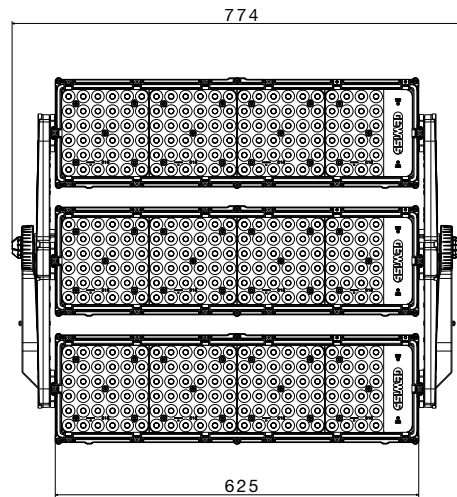
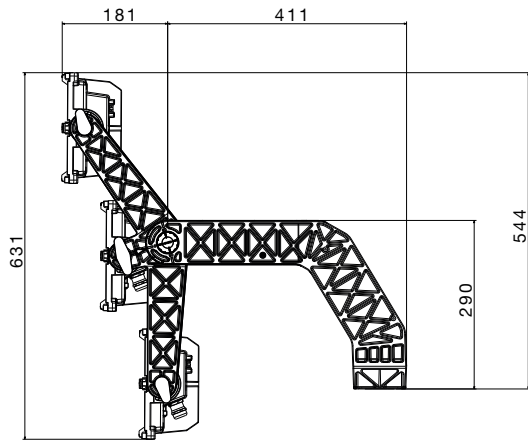

STADIUMPRO 13 +

GWP30001  
GWP30030  
GWP30031 (GWP30032)

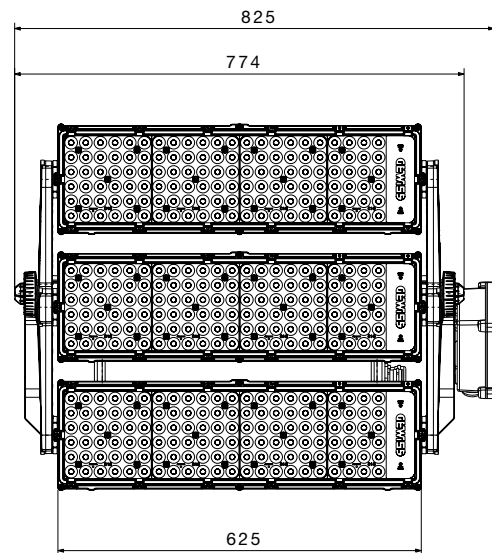
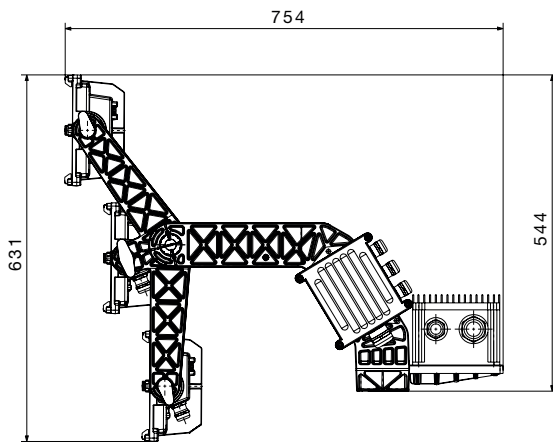
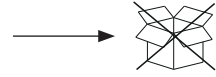

STADIUMPRO 13 +

GWP30005 GWP30033  
(GWP30035)  
(GWP30037)

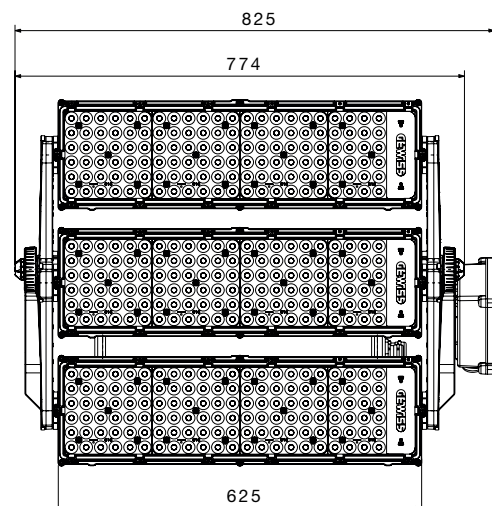
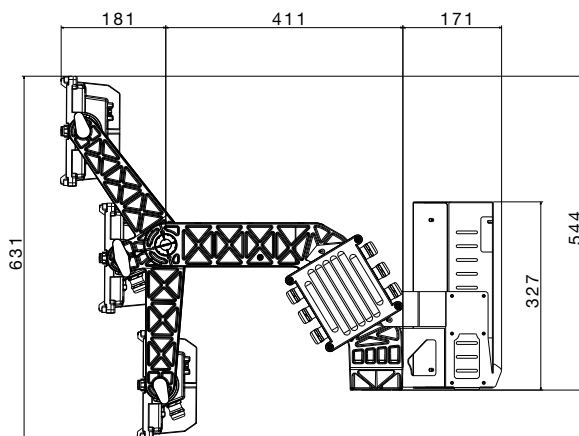
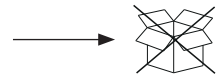

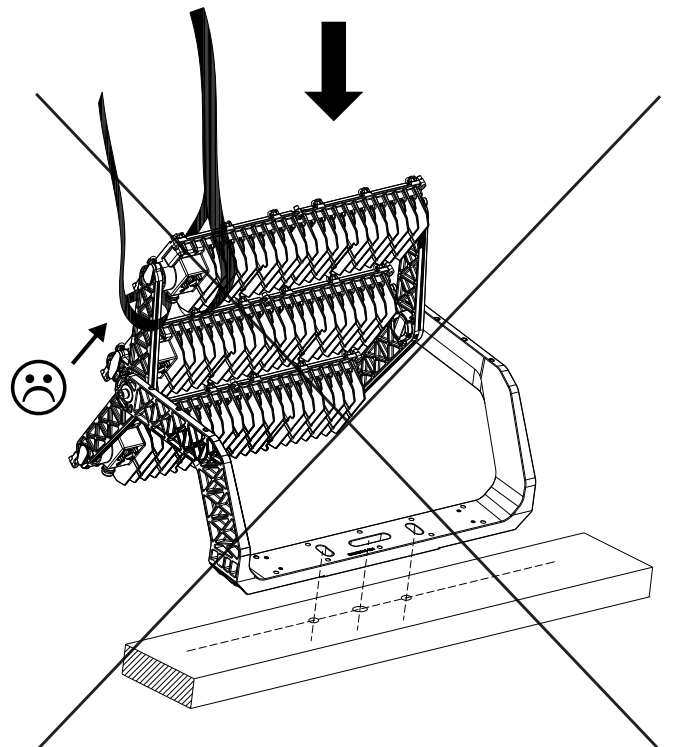
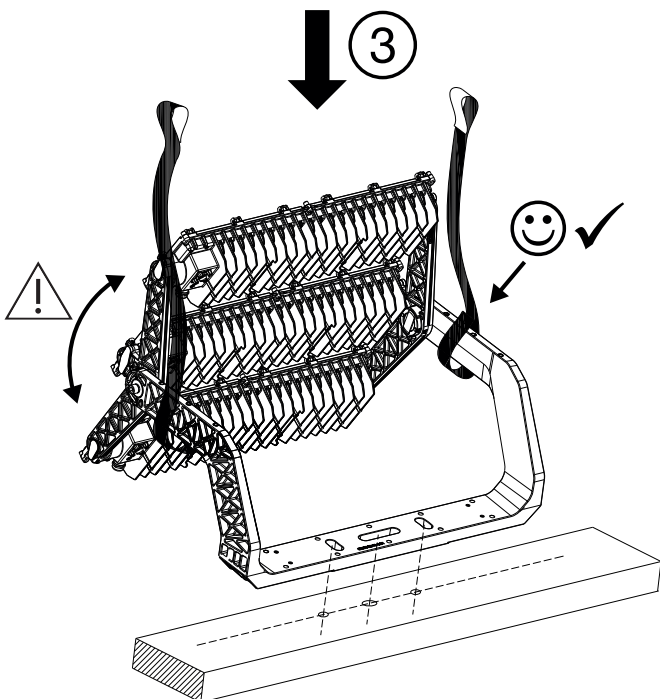
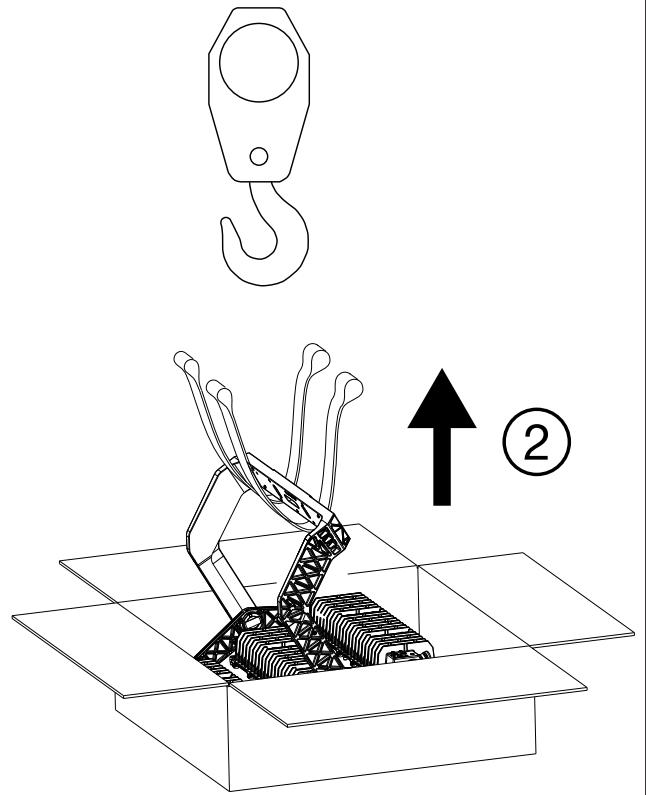
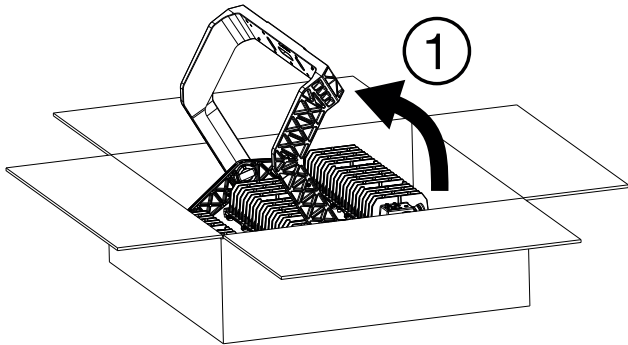

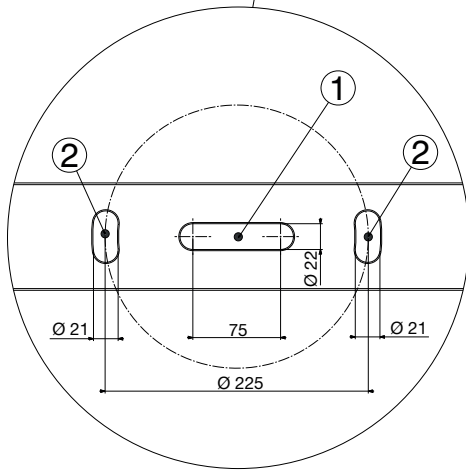
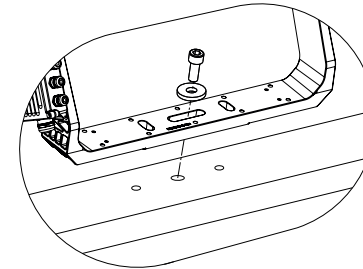
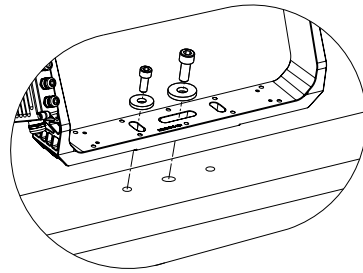
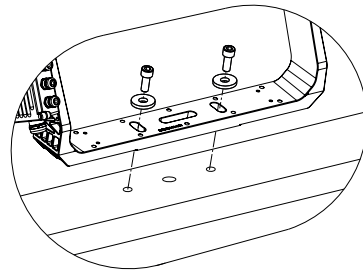
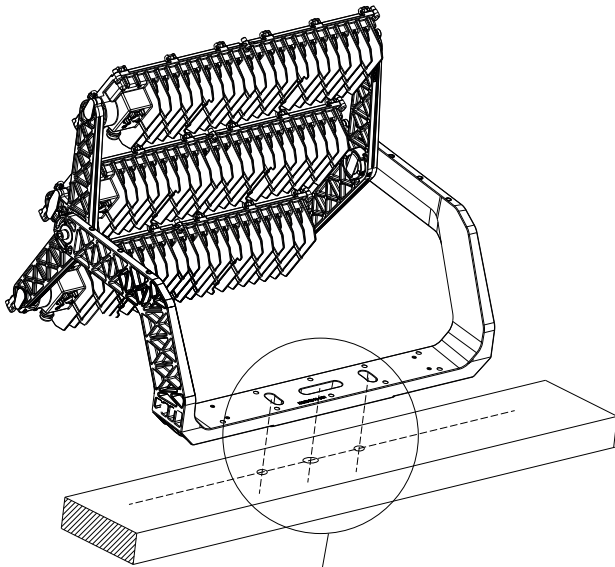

①		M20
		DIN9021
②		M16
		DIN9021

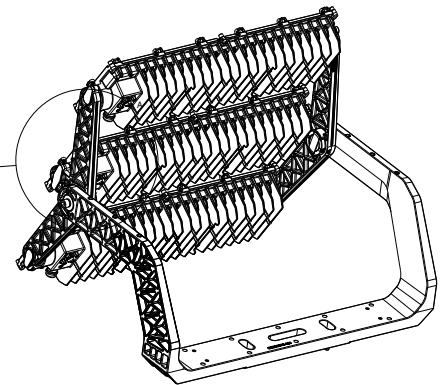
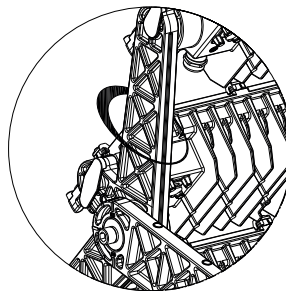
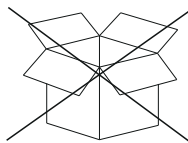

IT Per installazioni superiori a 3m assicurare il proiettore sulla spalla metallica con catena (es. GWS6922) o cavo di acciaio. -

AR إظهارا دن ع ڤڤالوف لباك وا (GWS6922 قباسرلا لڤڤولما) قلع لسب فاشرفاللا نڤم اقب بق برام 3 زواجتي عافترا على ع بڤڤورتالل

**BE** Для установки вышэй за 3 м замаўцеце пражэктар на раме з дапамогай ланцуга (раней GWS6922) або сталёвага кабеля. - **BG** За монтаж на височина, по-голяма от 3 метра, закрепете прожектора при рамката с верига (напр. GWS6922) или стоманен кабел. - **CS** Při instalaci do výšky větší než 3 metry zajistěte světlomet k rámečku pomocí řetězu (ex GWS6922) nebo ocelového lanka. - **DA** For installationer på over 3m skal projektøren fastgøres på metalansatsen med kæde (eks. GWS6922) eller stål kabel. - **DE** Bei Installationen über 3m den Scheinwerfer auf der Metallschulter mit Kette (Bsp. GWS6922) oder Stahlseil sichern. - **EL** Για εγκαταστάσεις άνω των 3 μέτρων στερεώστε τον προβολέα στη μεταλλική βάση με αλυσίδα (π.χ. GWS6922) ή σιματόσχοινο. - **EN** For installation higher than 3m secure the floodlight at the frame with chain (ex GWS6922) or steel cable. - **ES** Para instalaciones superiores a 3m, asegurar el proyector en el soporte metálico con cadena (por ej.: GWS6922) o cable de acero. - **ET** Paigaldamiseks kõrgemale kui 3 m kinnitage prožektor raami külge keti (nt GWS6922) või teraskaabli abil. - **FI** 3 metriä ylittävälle asennuksille valonheittimen kiinnitys metallitukeen on varmistettava ketjulla (esim. GWS6922) tai teräskaapelilla. - **FR** Pour les installations de plus de 3 m, fixer le projecteur sur l'épaulement métallique avec une chaîne (p. ex. GWS6922) ou un câble en acier. - **GA** Má táthar chun é a shuiteáil níos airde ná 3m, daingnigh an tuilsolas ag an bhfráma le slabhra (m. sh. GWS6922) nó le cábla cruach. - **HR** Kod postavljanja na visini većoj od 3 m učvrstite reflektor na metalnom okviru pomoću lanca (npr. GWS6922) ili čeličnog kabela. - **HU** 3 méteren túllépő telepítések esetén biztosítsa ki a fényvetőt a fémtartón láncsal (pl. GWS6922) vagy acélkábellel. - **KK** 3 метрден жоғары биіктікке орнатылатын болса, прожекторды жақтауға шыңжыр (ex GWS6922) немесе болат арқанның көмегімен бекітіңіз. - **LT** Jei norite įrengti prožektorių aukščiau nei 3 m, pritvirtinkite jį prie rėmo su grandine (pvz. GWS6922) arba plieniniu kabeliu. - **LV** Uzstādot augstumā, kas lielāks par 3 m, nostipriniet prožektora gaismu, pie rāmja pievienojot ķēdi (piem., GWS6922) vai tērauda trosi. - **MT** Għal installazzjoni f'għoli ta' aktar minn 3 m, waħħal il-floodlight mill-frejim b'katina (ex GWS6922) jew b'kejbil tal-azzar. - **NL** Voor installaties hoger dan 3m moet het spreidlicht op de metalen houder met ketting (es. GWS6922) of stalen kabel bevestigd worden. - **NO** For installasjoner over 3 m må projektoren sikres på metallanslag med kjede (f.eks. GWS6922) eller stålkabel. - **PL** W instalacjach powyżej 3 m przymocować projektor na metalowym ramieniu łańcuchem (np. GWS6922) lub stalowym kablem. - **PT** Para instalaçãoes acima de 3 m, prenda o projetor no suporte metálico com corrente (p. ex., GWS6922) ou cabo de aço. - **RO** Pentru instalarea la o înălțime mai mare de 3m asigurați proiectorul de cadru cu un lanț (ex GWS6922) sau un cablu de oțel. - **RU** При установке выше 3м закрепите прожектор на металлическом кронштейне цепью (например, GWS6922) или стальным тросом. - **SK** Při inštalácii do výšky väčšej než 3 metre zaistite svetlomet k rámečku pomocou reťaze (ex GWS6922) alebo ocelového lanka. - **SL** Za montažo višje 3 m projektor pritrdite na kovinsko konzolo z verigo (npr. GWS6922) ali jekleno vrvjo. - **SV** För installationer högre än 3 meter ska strålkastarens metallram säkras med kedja (t.ex. GWS6922) eller stålvajer. - **TR** 3m'den daha yüksek bir konuma montaj için, projektörü çerçeveye zincir (örn. GWS6922) ya da çelik kablo ile sabitleyin. - **ZH** 如果在 3m 以上高度安装, 则应使用链条 (ex GWS6922) 或钢缆, 将泛光灯固定于车架。

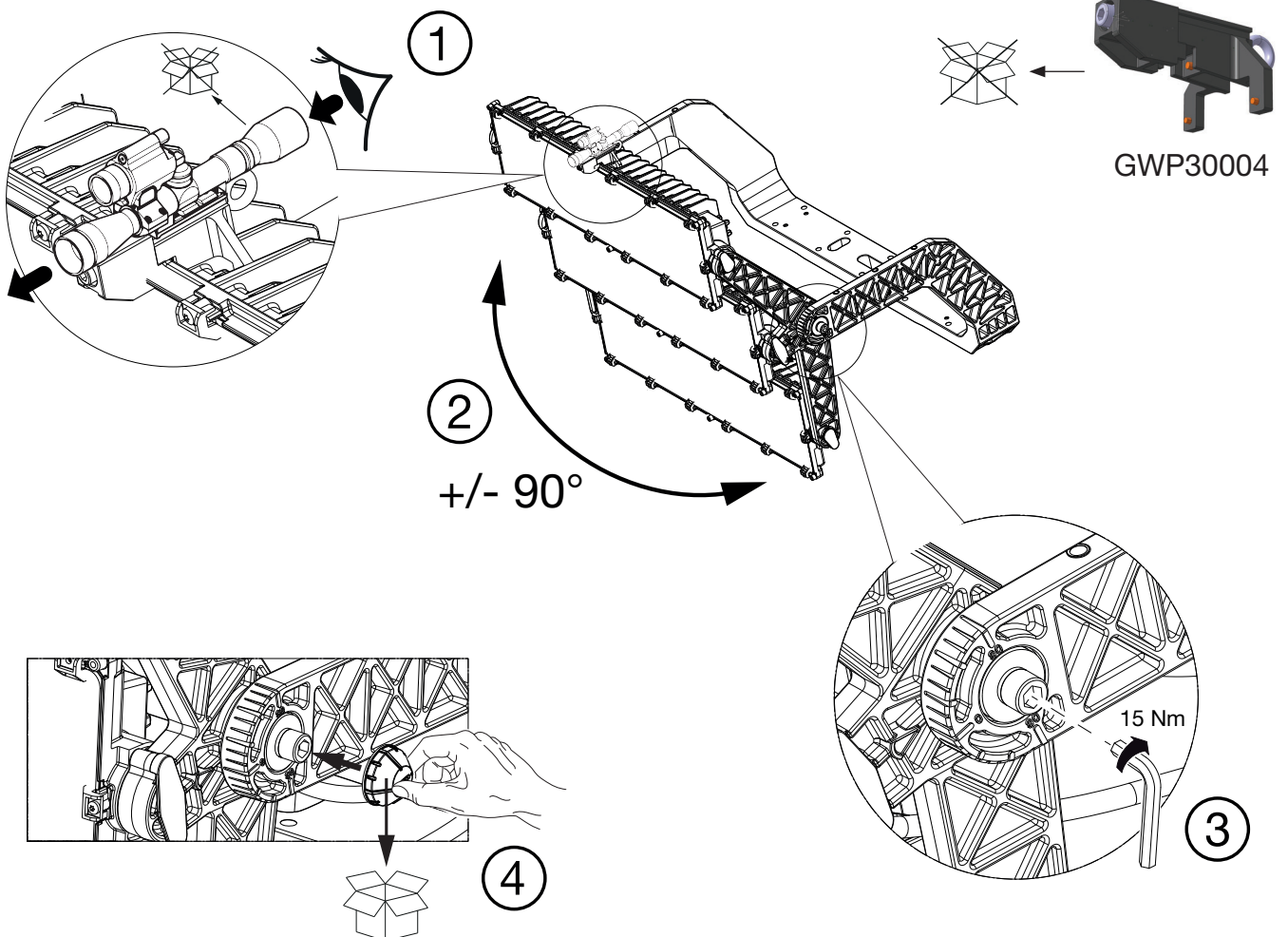
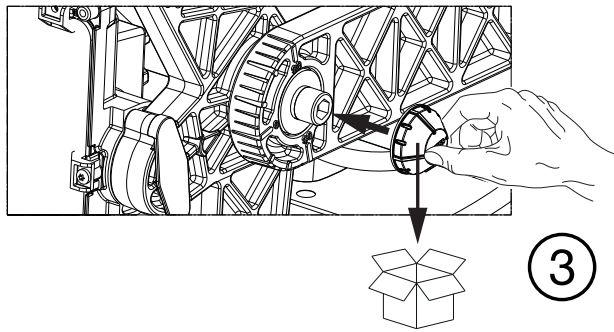
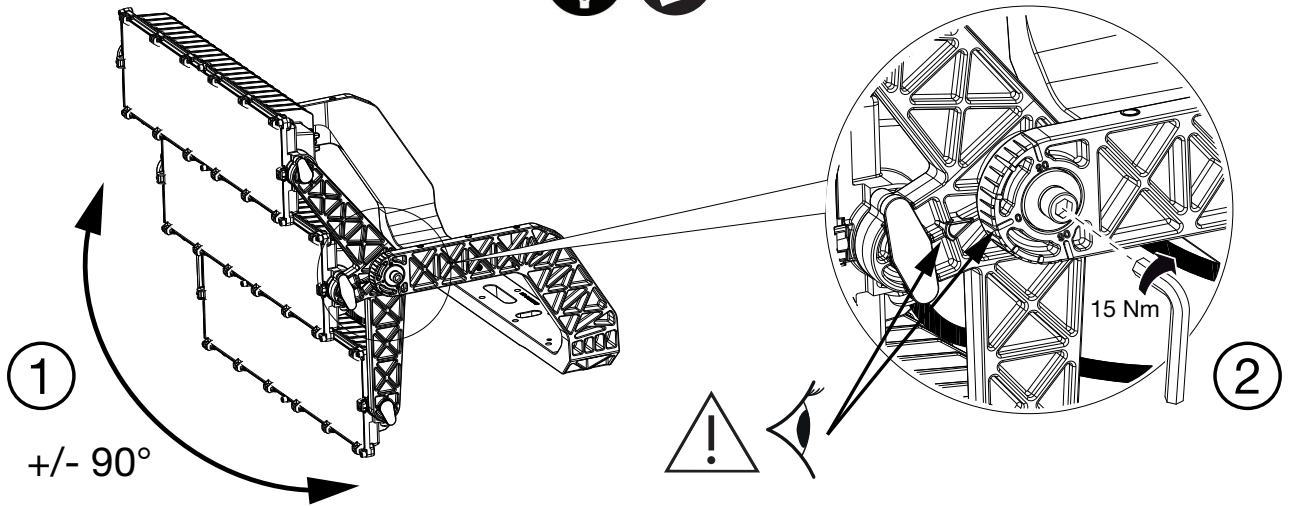

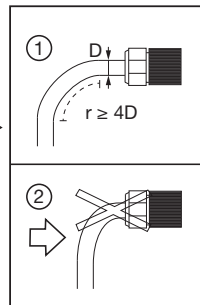
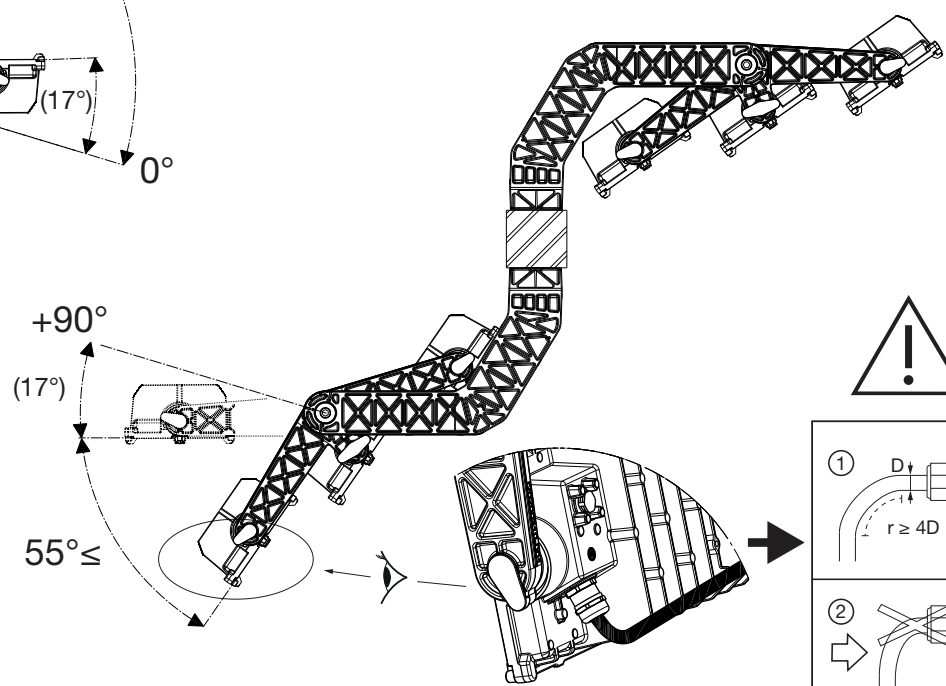
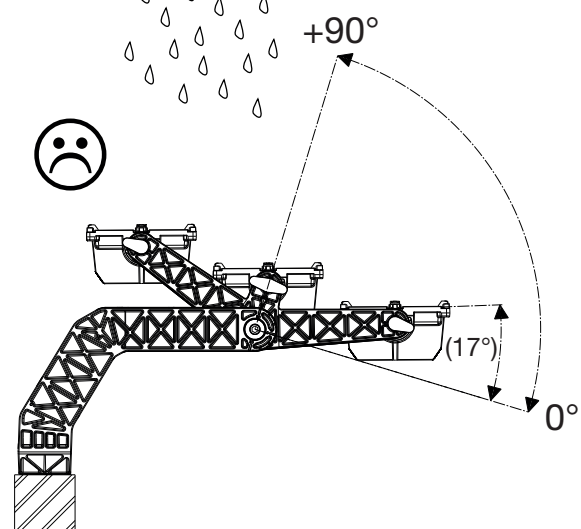
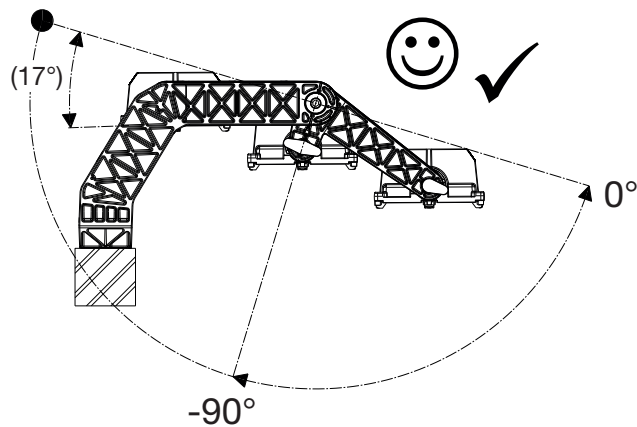
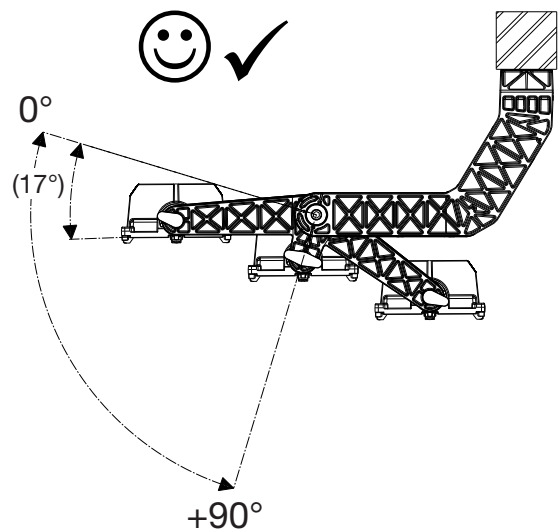
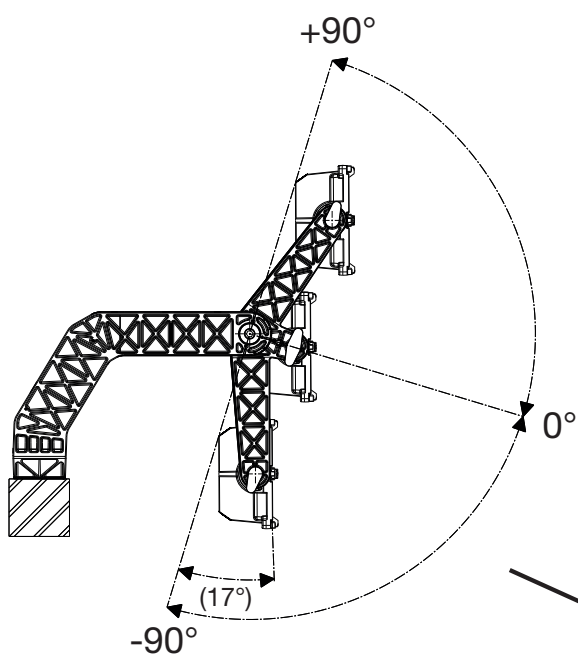



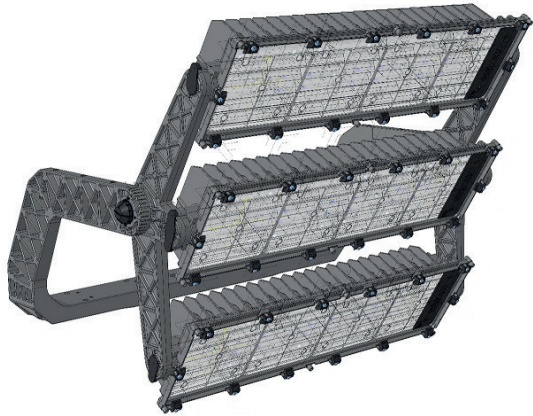

A1

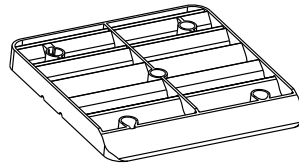

A2

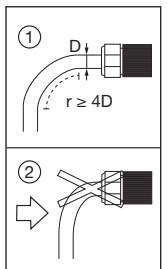
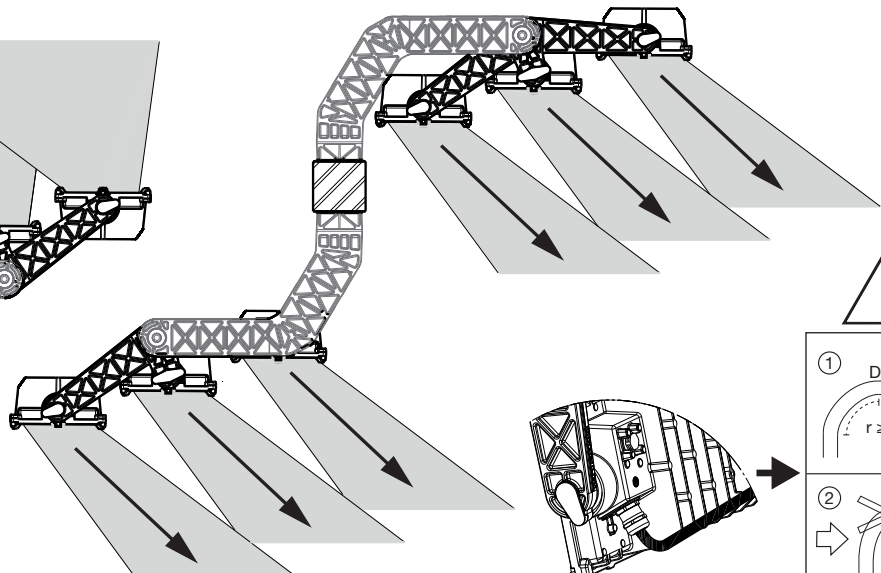
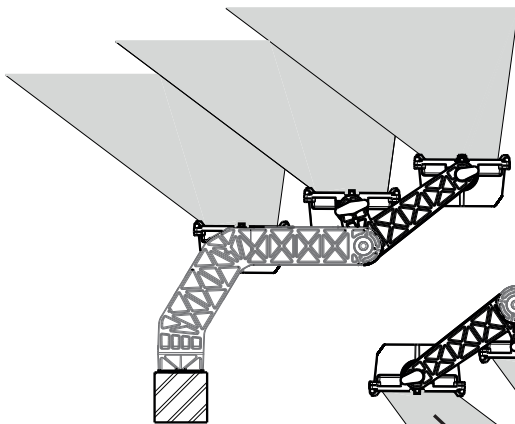
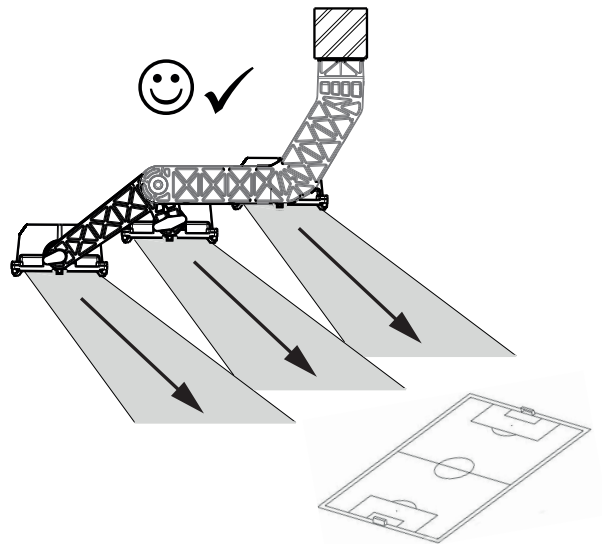
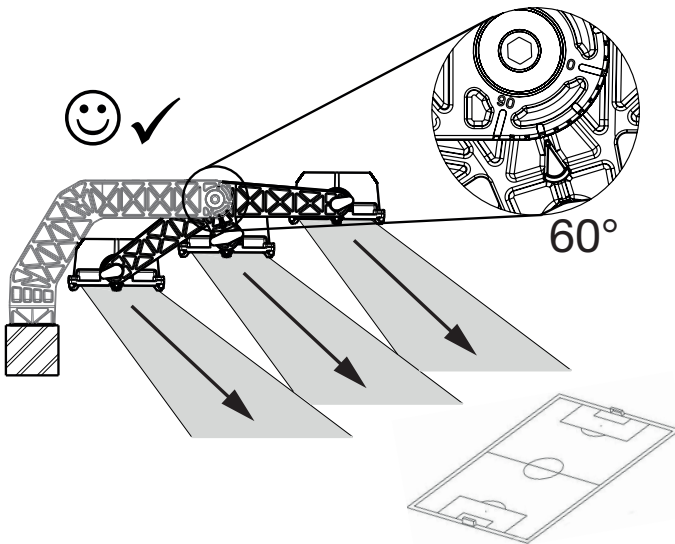
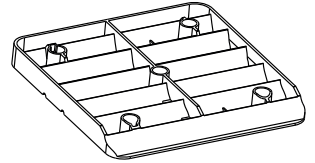

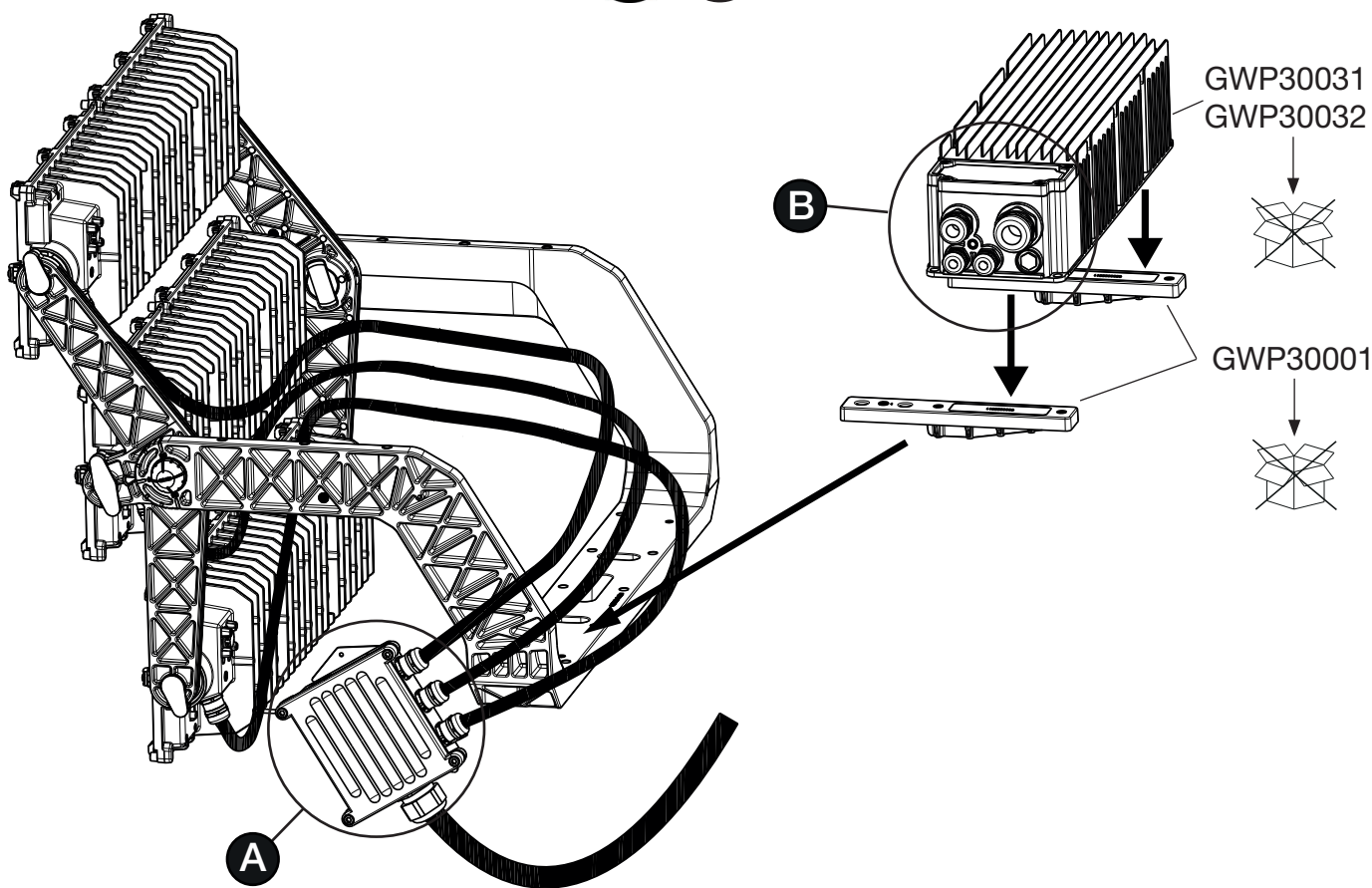

**A** GWP30030 →



		DALI / DMX		
	+	=	L	
	-	=	N	
	⊕	=	⊕	
	①	=	DA+	
	②	=	DA-	

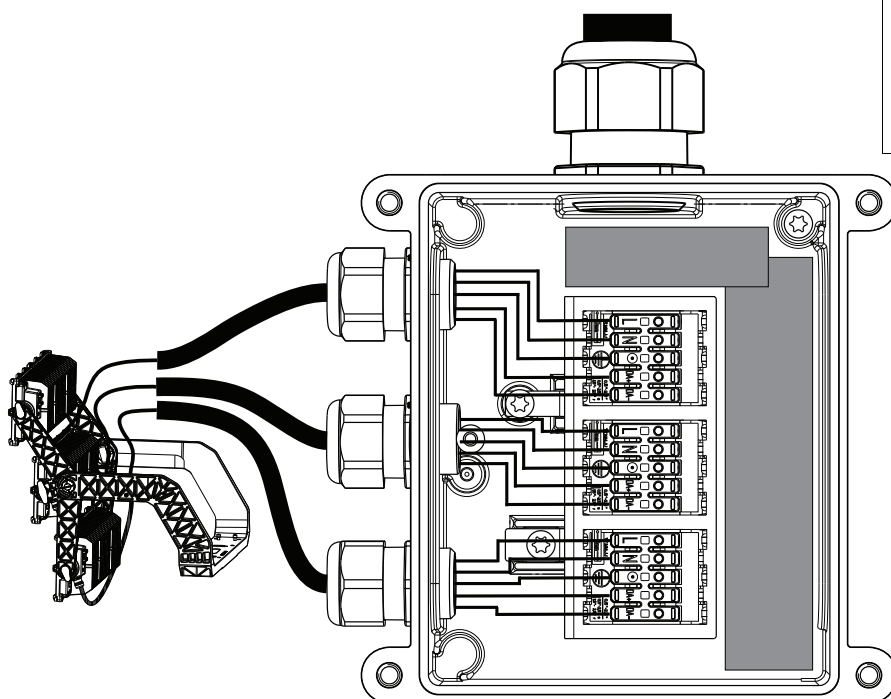



**B**

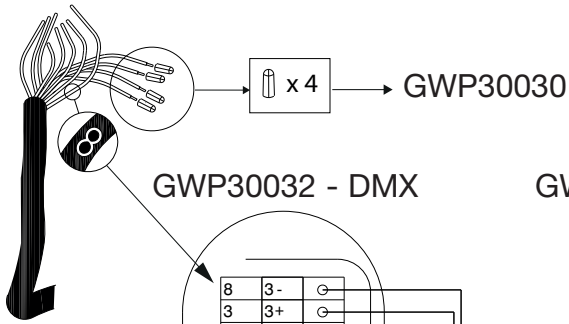

GWP30032 - DMX

GWP30031 - DALI

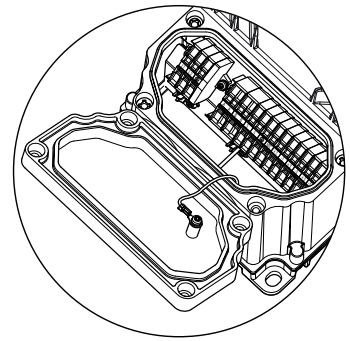
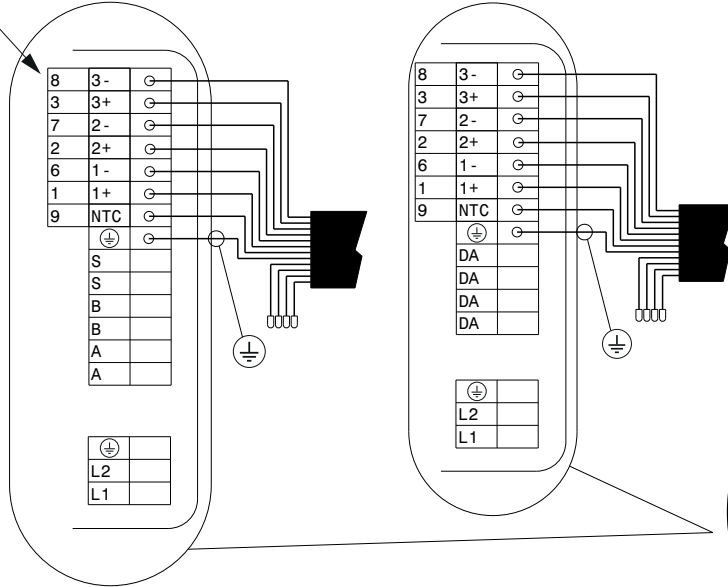

GWP30031 - DALI

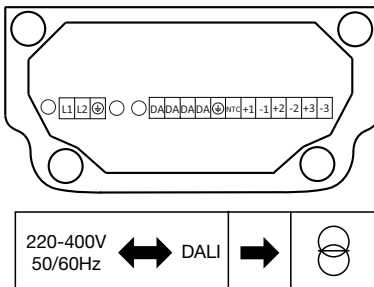

PINOUT		
Number	Label	
1	L1	AC L1 IN
2	L2	AC L2 IN
3	⊕	PE
4	DA	DALI 1
5	DA	DALI 1
6	DA	DALI 2
7	DA	DALI 2
8	⊕	PE
9	NTC	NTC
10	+1	LED1+
11	-1	LED1-
12	+2	LED2+
13	-2	LED2-
14	+3	LED3+
15	-3	LED3-

GWP30032 - DMX  
DMX address default: 1

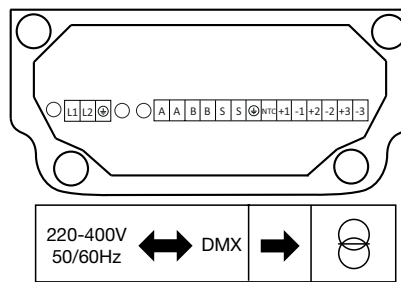

PINOUT		
Number	Label	
1	L1	AC L1 IN
2	L2	AC L2 IN
3	⊕	PE
4	A	DMX A input/relaunch
5	A	DMX A input/relaunch
6	B	DMX B input/relaunch
7	B	DMX B input/relaunch
8	S	DMX shield
9	S	DMX shield
10	⊕	PE
11	NTC	NTC
12	+1	LED1+
13	-1	LED1-
14	+2	LED2+
15	-2	LED2-
16	+3	LED3+
17	-3	LED3-



ta +35°C

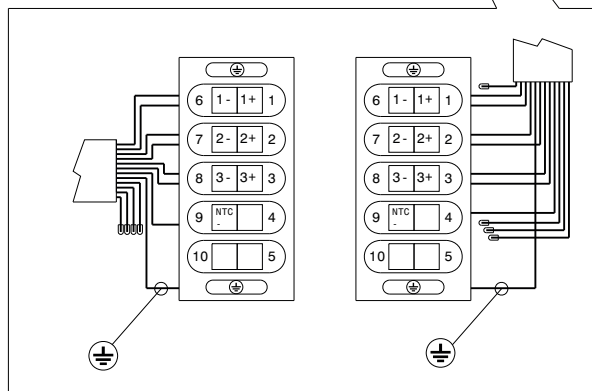
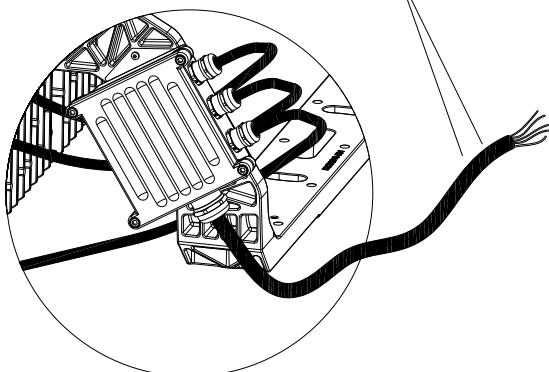
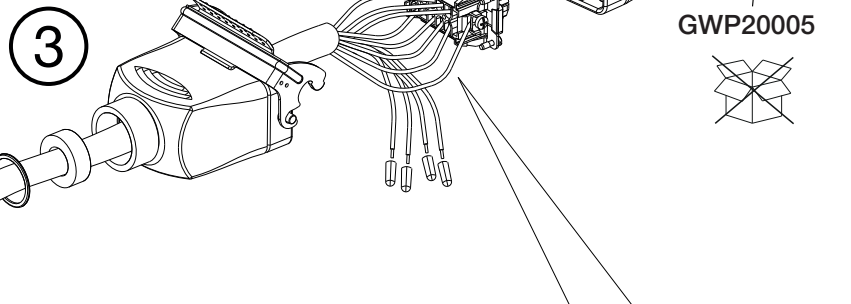
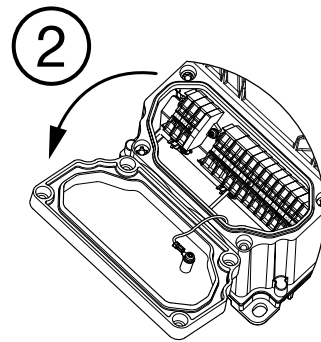
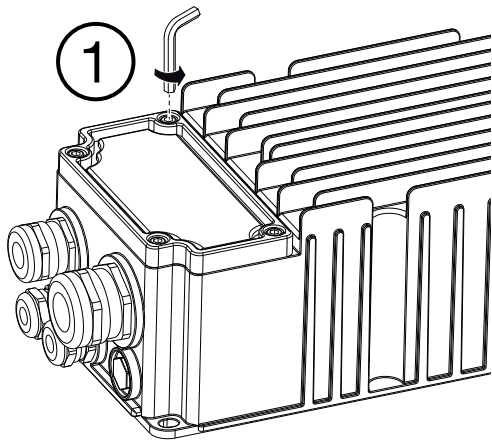
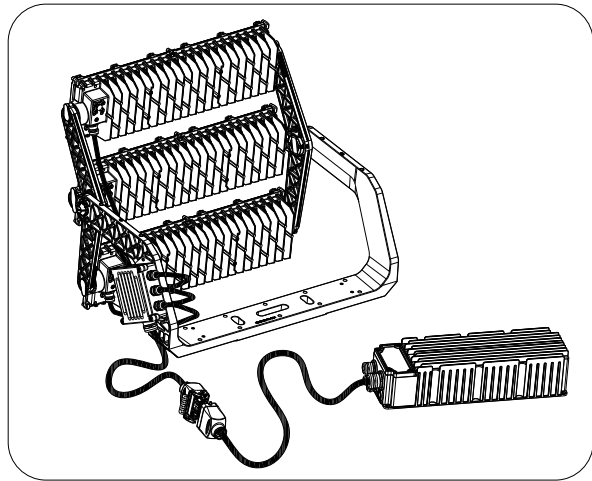
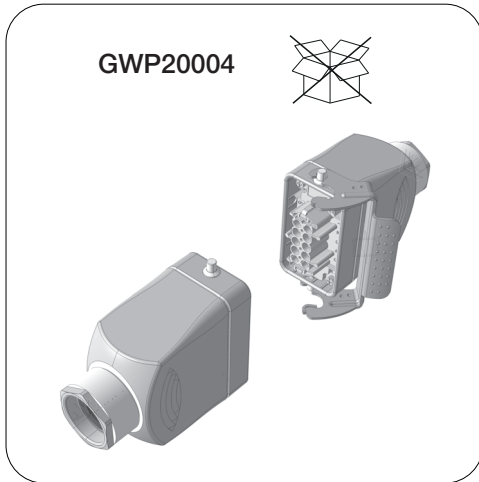



H07RN-F 12x1,5 (Max 50 m)

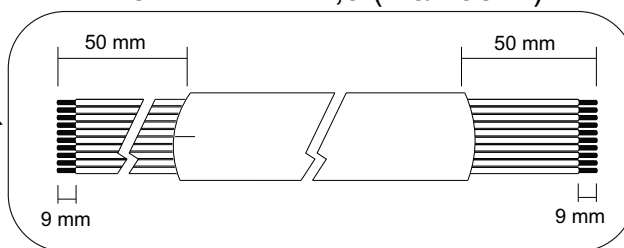

GWP20005

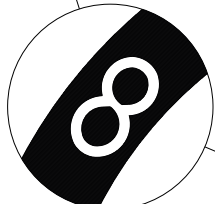
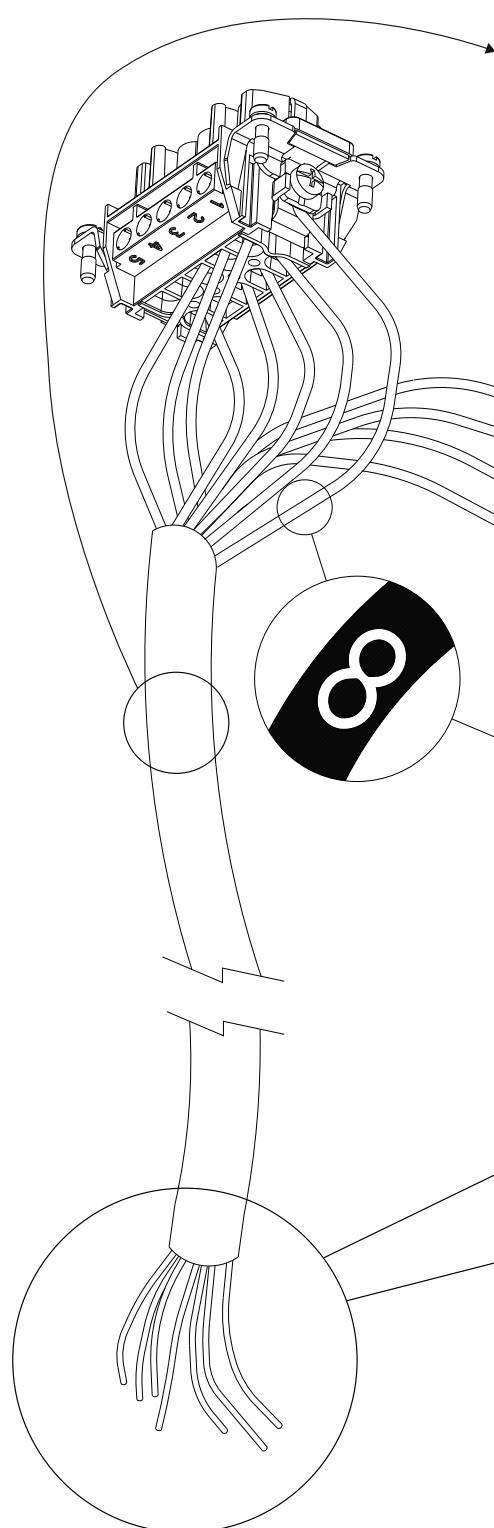

GWP30031 - DALI

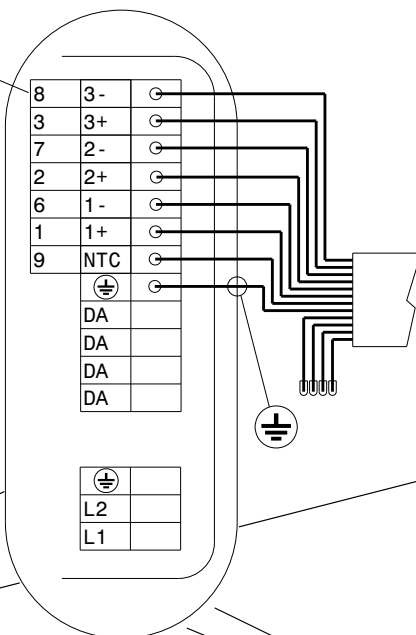

GWP30032 - DMX

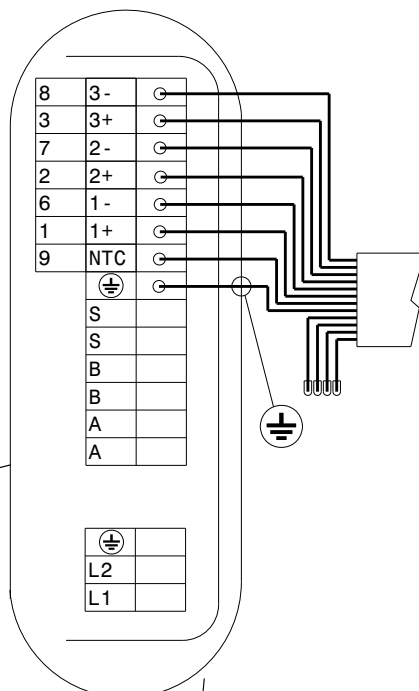

4

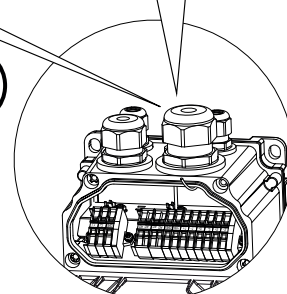

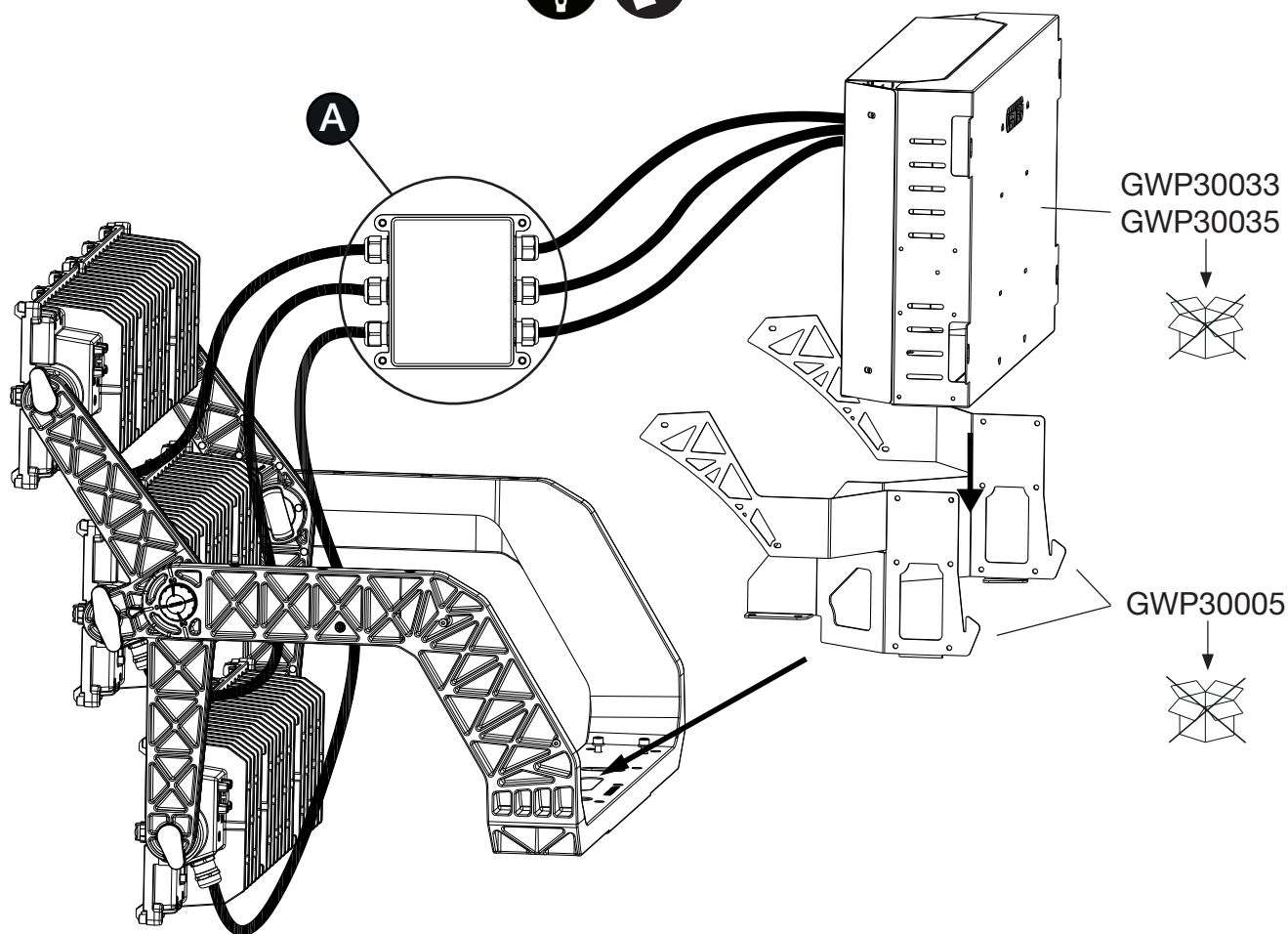

**A** GWP30037 →



DALI / 0-10V			
+	= L	=	+
-	= N	=	-
⊕	= ⊕	=	⊕
①	= DA+	=	①
②	= DA-	=	②

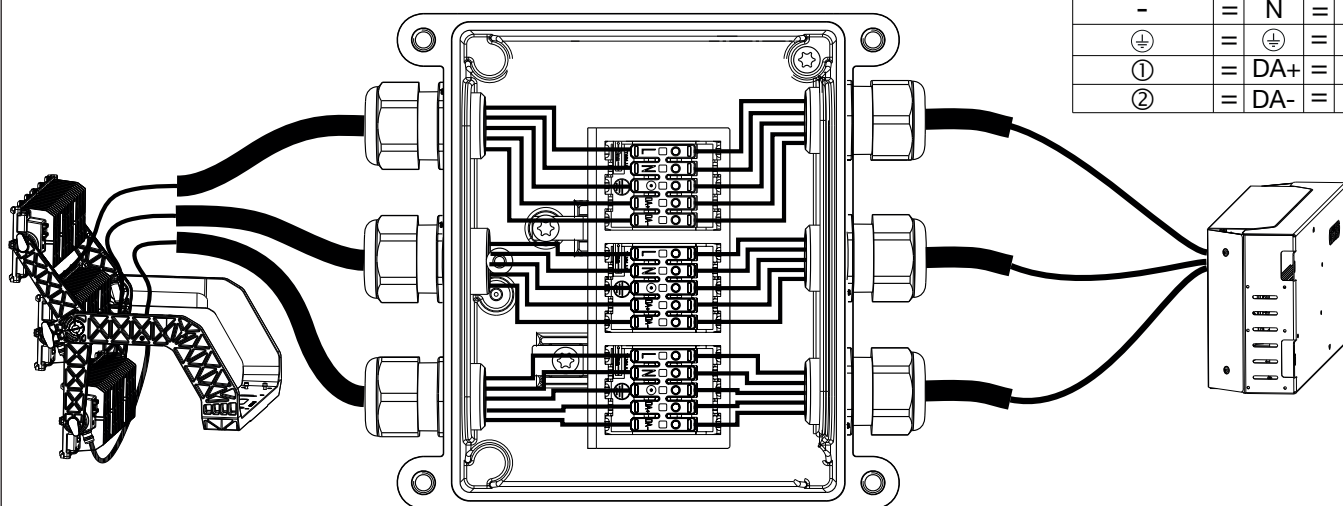

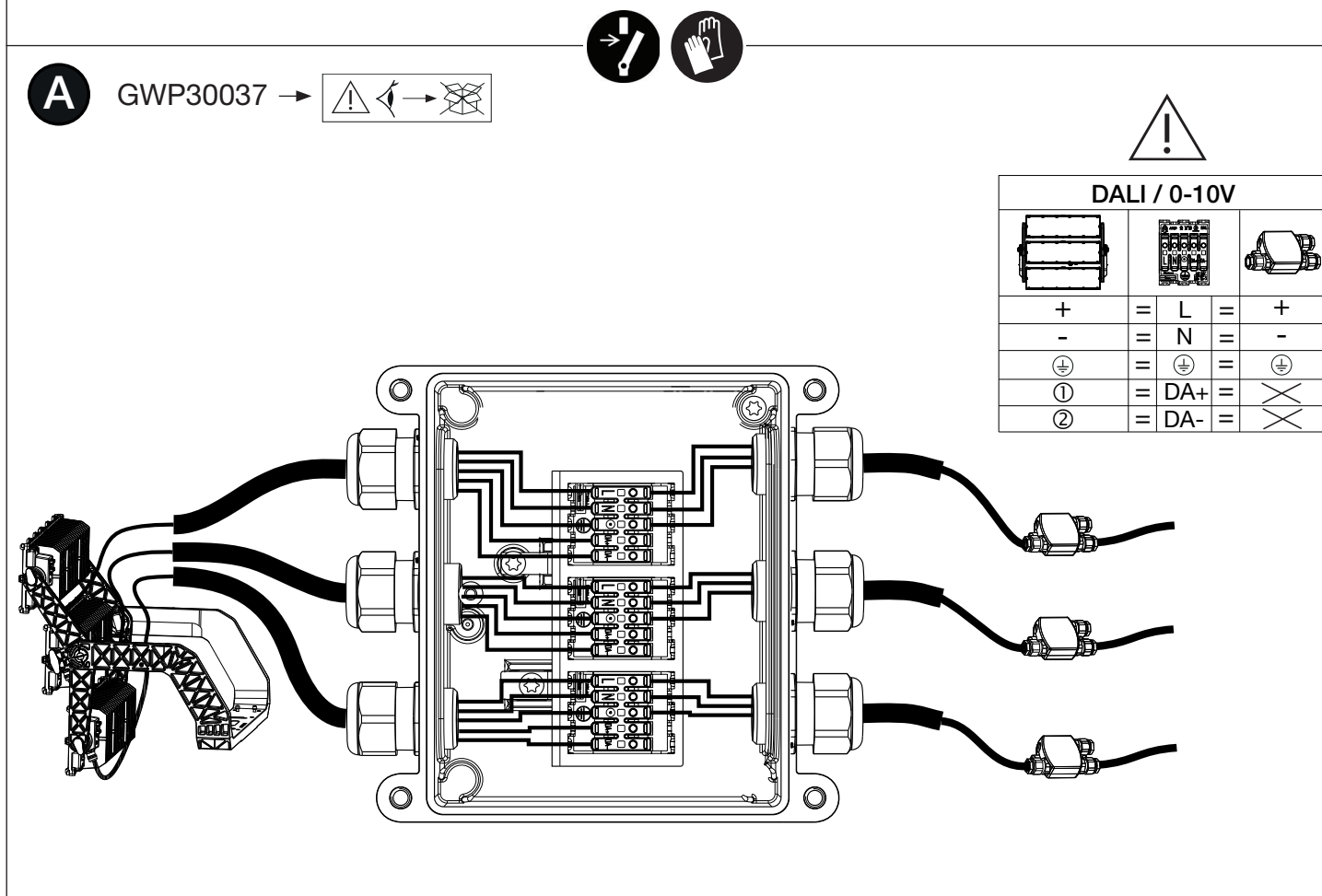
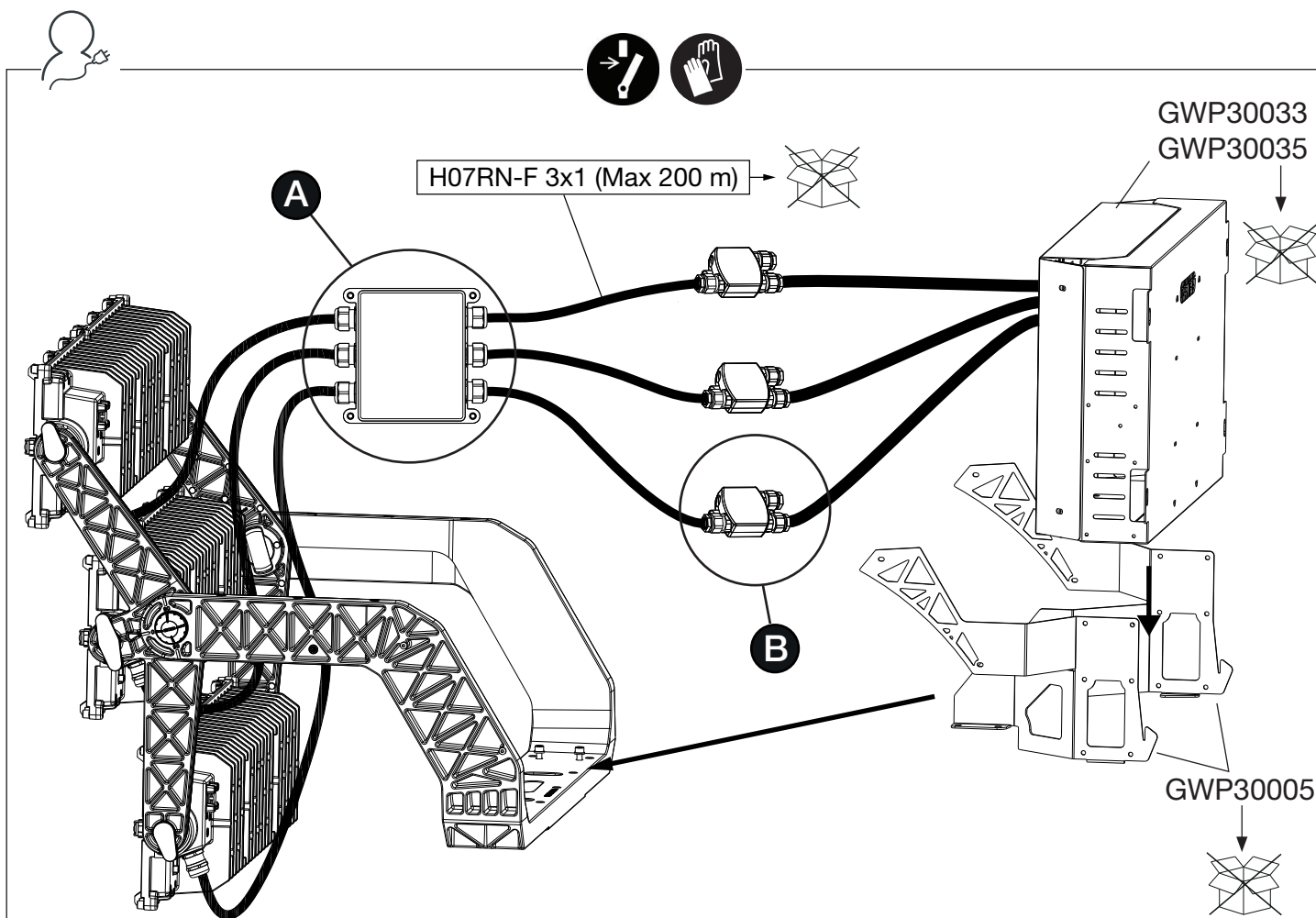



**B** GWP20113 →

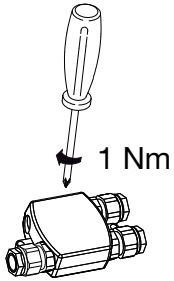

DALI / 0-10V		
	=	LED+
	=	LED-
	=	
	=	①
	=	②

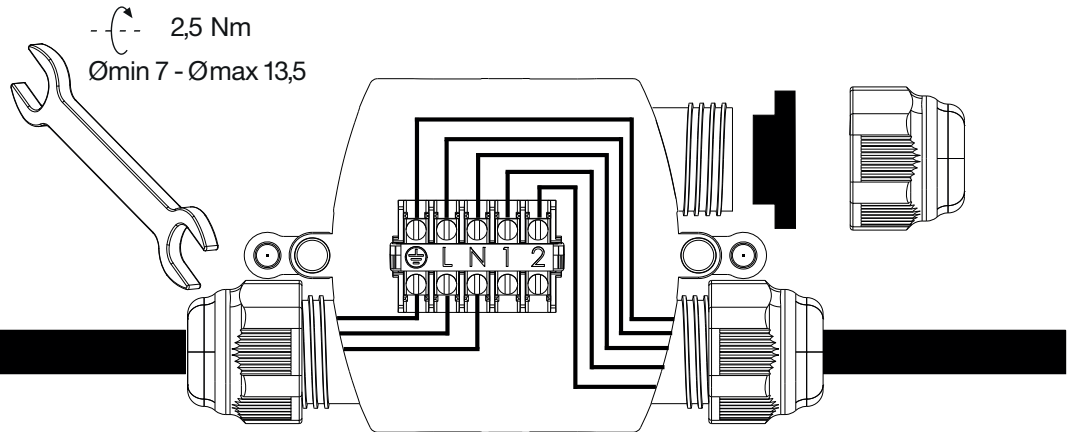





**B**

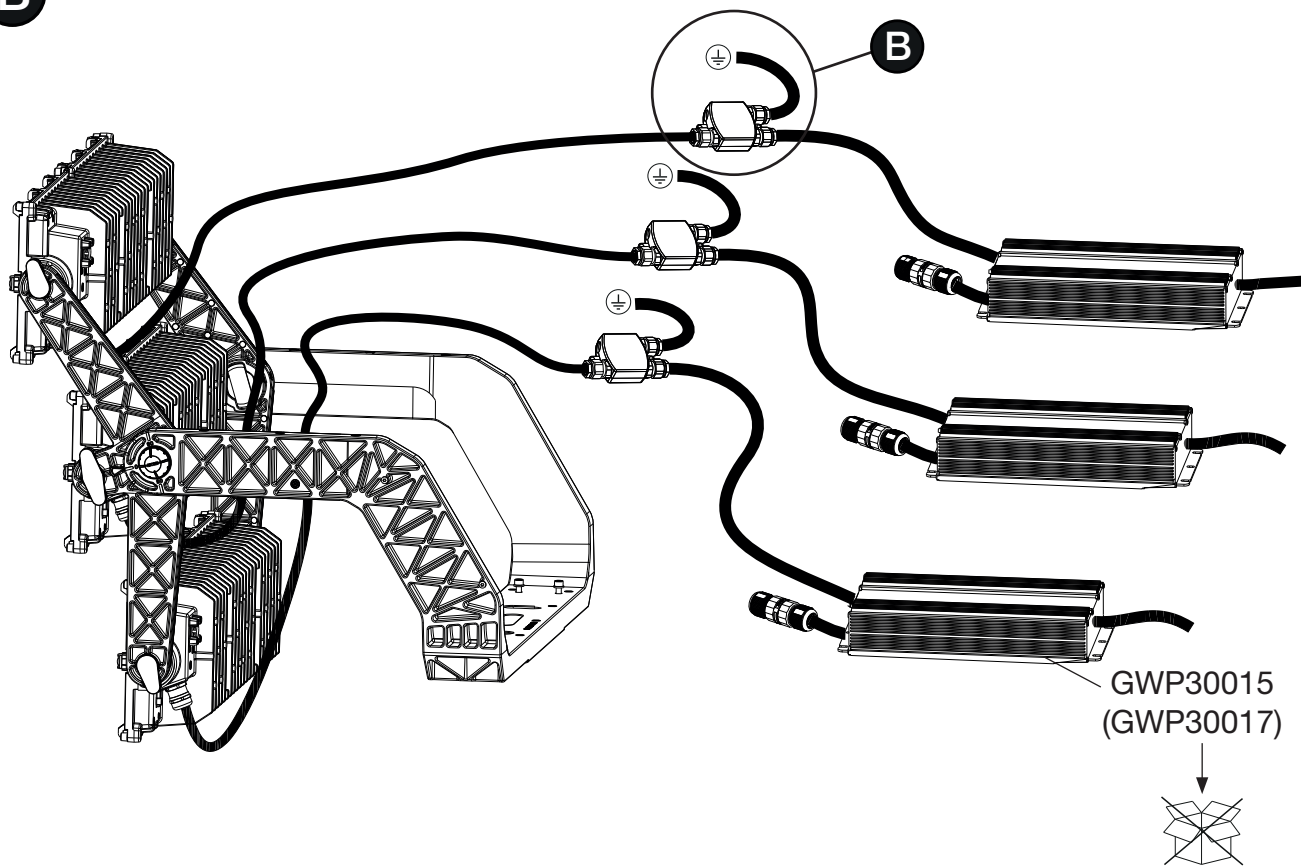

**B**

GWP20113 →

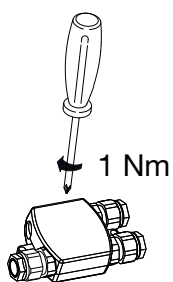

DALI / 0-10V			
L	=	LED+	
N	=	LED-	
⊕	=	⊕	
①	=	⊗	
②	=	⊗	

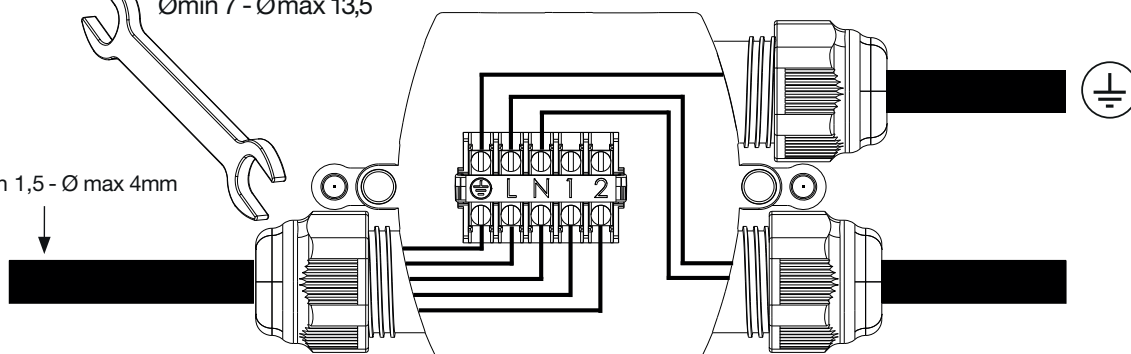
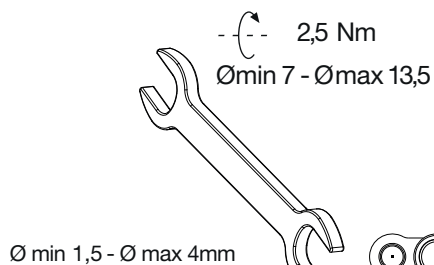

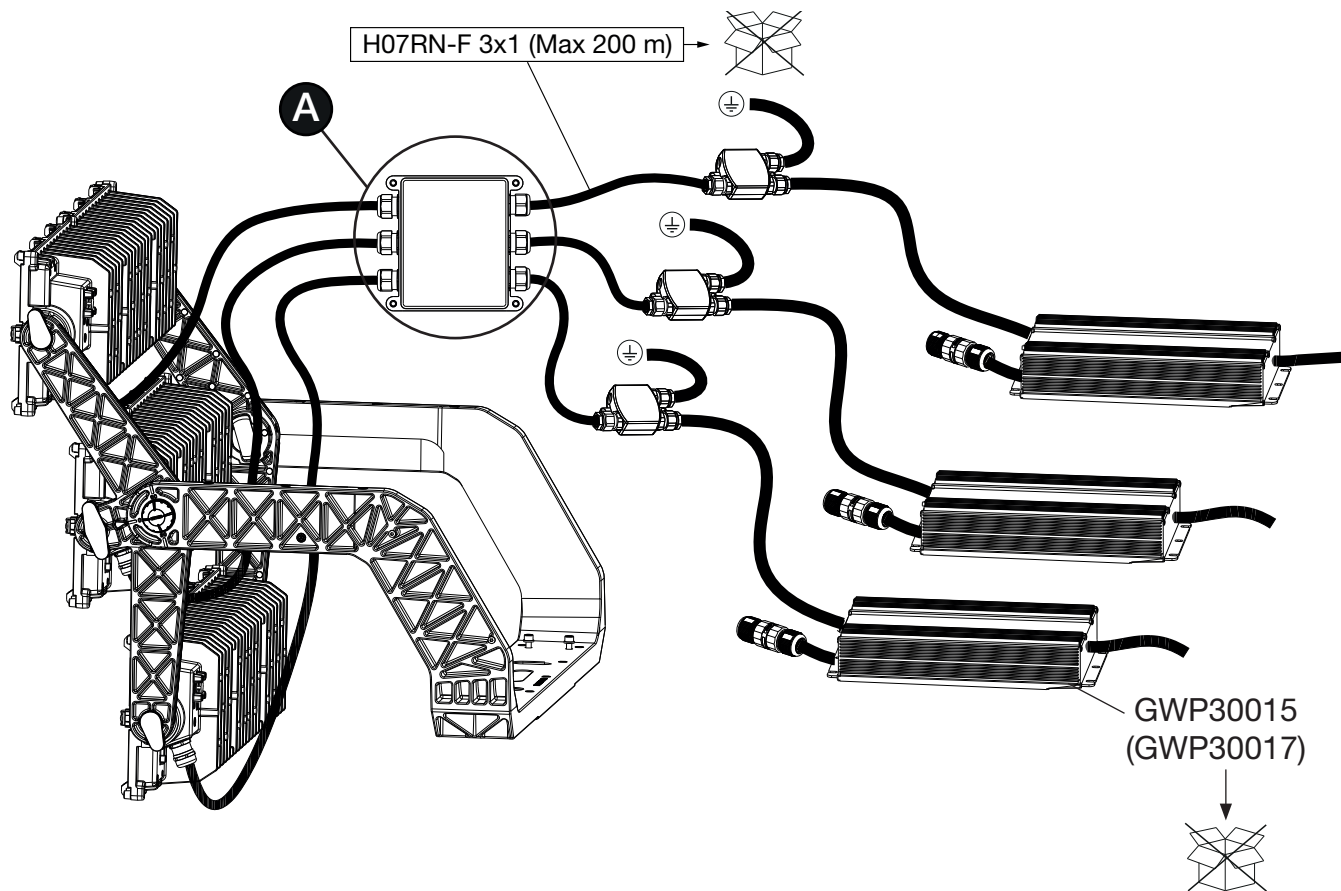

**A** GWP30037 →



DALI / 0-10V	
L	= LED+
N	= LED-
⊕	= ⊕
①	=
②	=

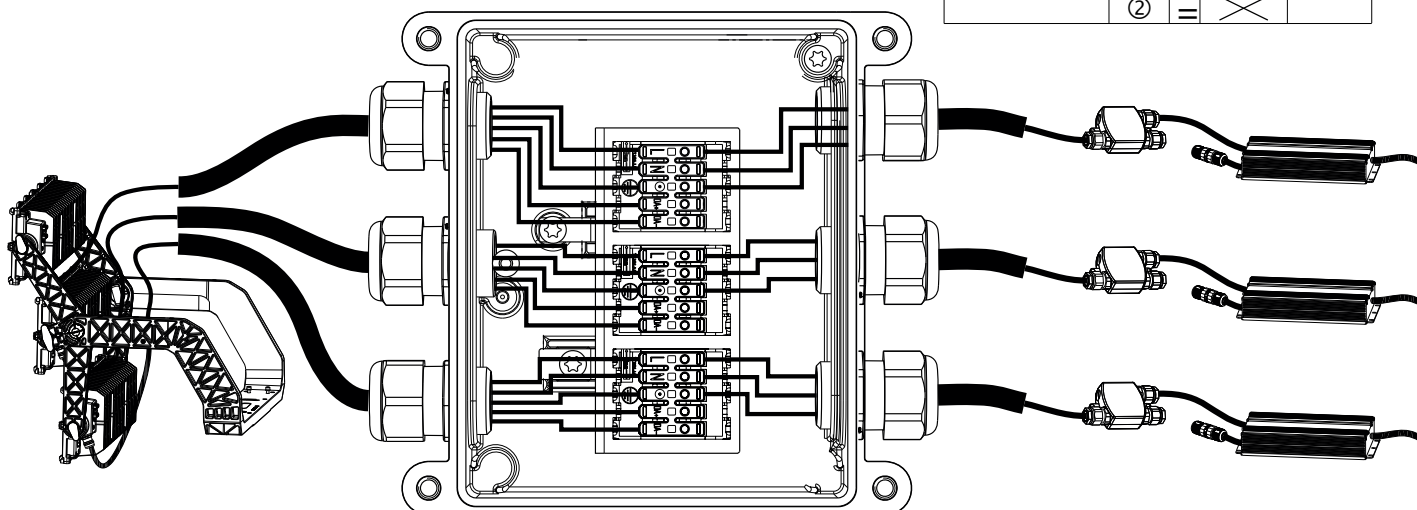

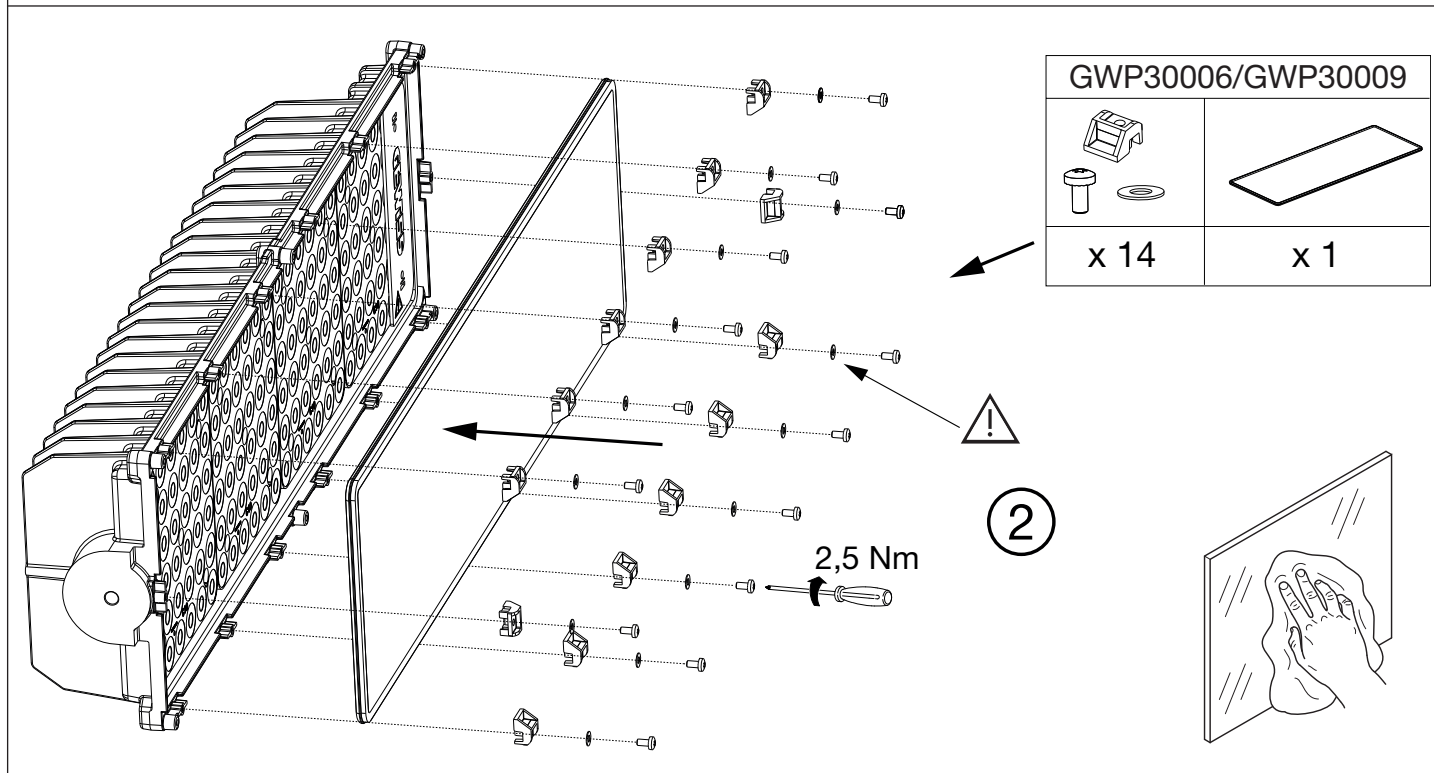
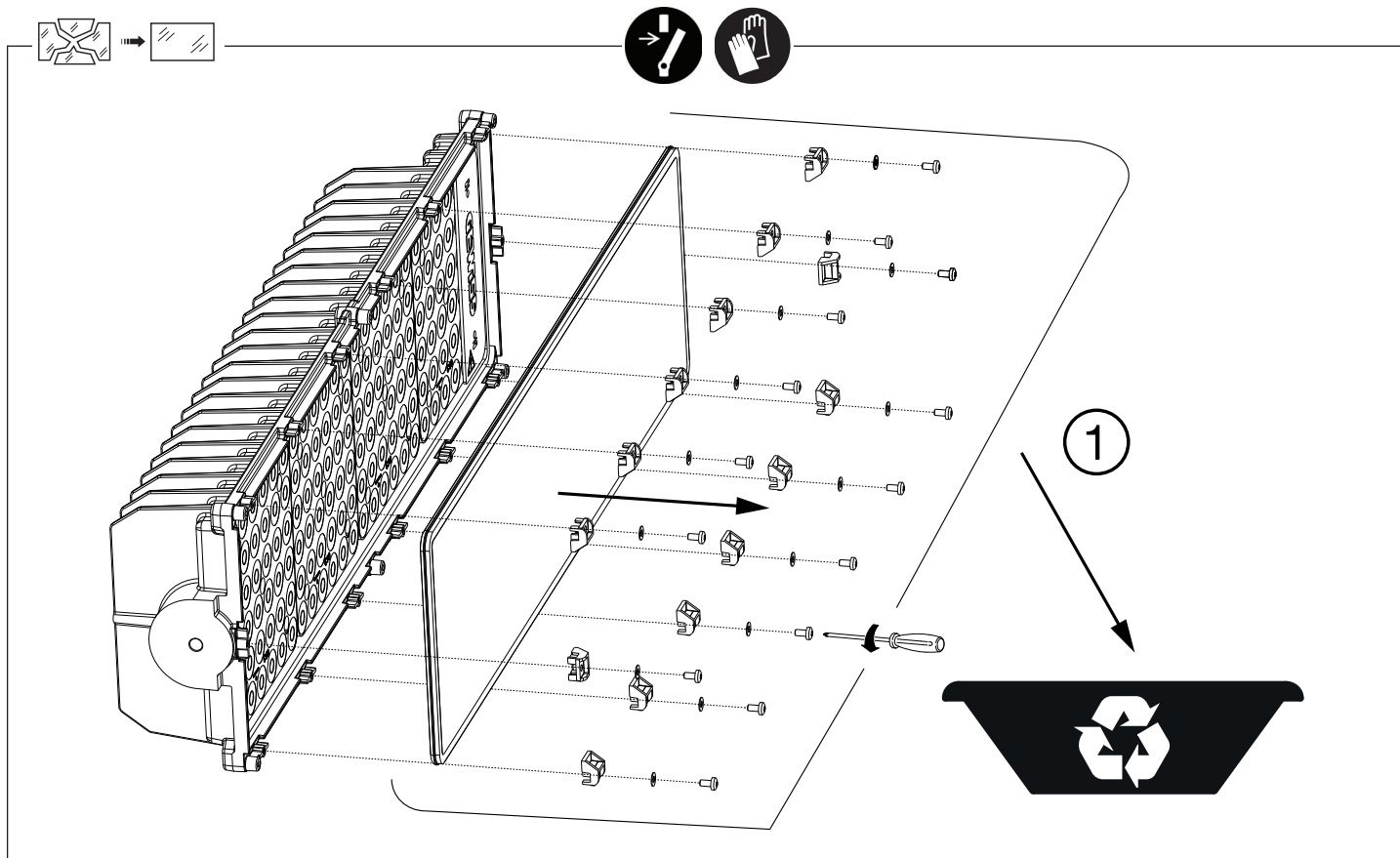



	OPTICS								
	S1	A1	A2	C1	C2	C3	C4	C5	C6
GWP30006	✓			✓	✓	✓	✓	✓	✓
GWP30009		✓	✓						

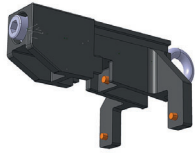

## Standard Picatinny



GWP30004

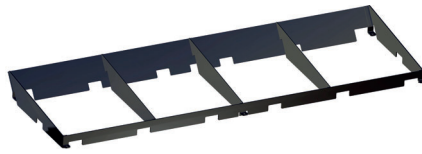

GWP30003

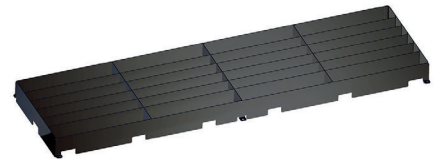

GWP30002

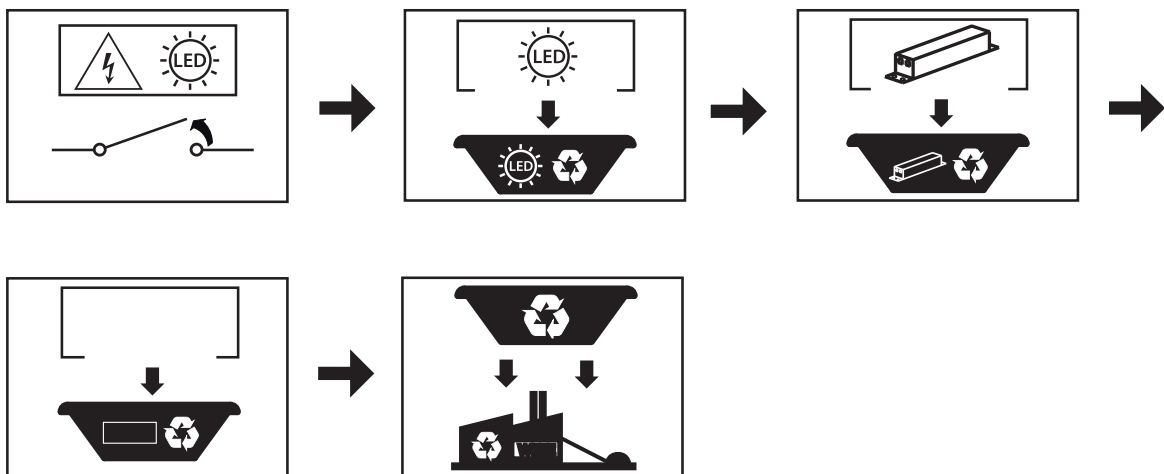
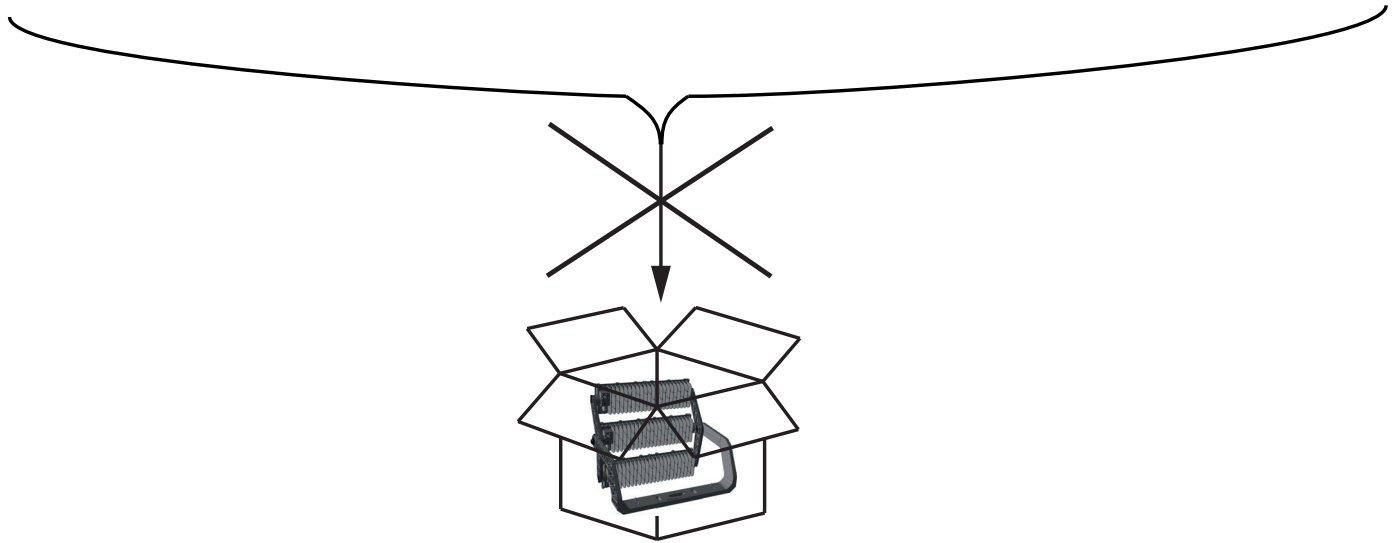

Punto di contatto indicato in adempimento ai fini delle direttive e regolamenti UE applicabili:  
 Contact details according to the relevant European Directives and Regulations:  
 GEWISS S.p.A. Via D.Bosatelli, 1 IT-24069 Cenate Sotto (BG) Italy tel: +39 035 946 111 E-mail: qualitymarks@gewiss.com

According to applicable UK regulations, the company responsible for placing the goods in UK market is:  
 GEWISS UK LTD - Unity House, Compass Point Business Park, 9 Stocks Bridge Way, ST IVES  
 Cambridgeshire, PE27 5JL, United Kingdom tel: +44 1954 712757 E-mail: gewiss-uk@gewiss.com

**+39 035 946 111**  
 8:30 - 12:30 / 14:00 - 18:00  
 lunedì - venerdì / monday - friday

[www.gewiss.com](http://www.gewiss.com)

