

1

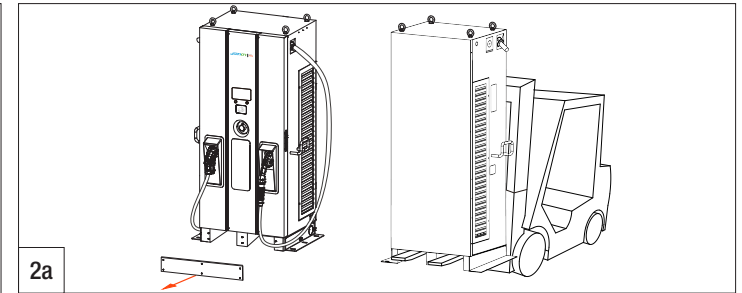

2a

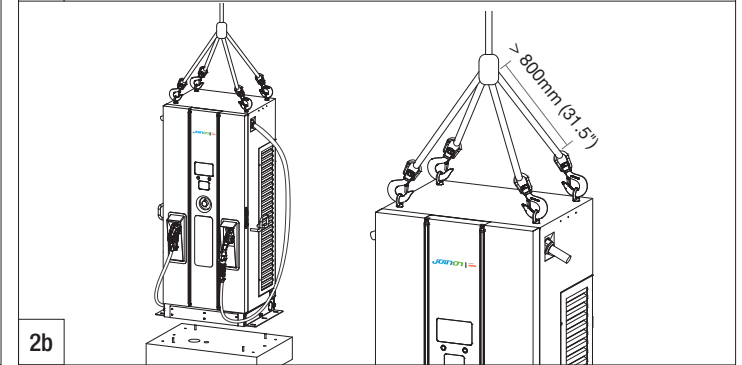

2b

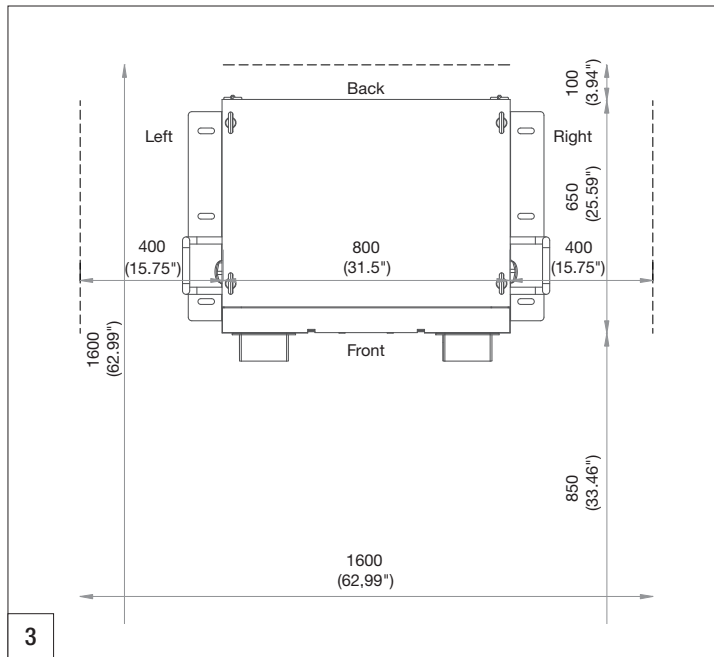

3

Quick installation guide I-FAST 90-180 KW (Floor Version)

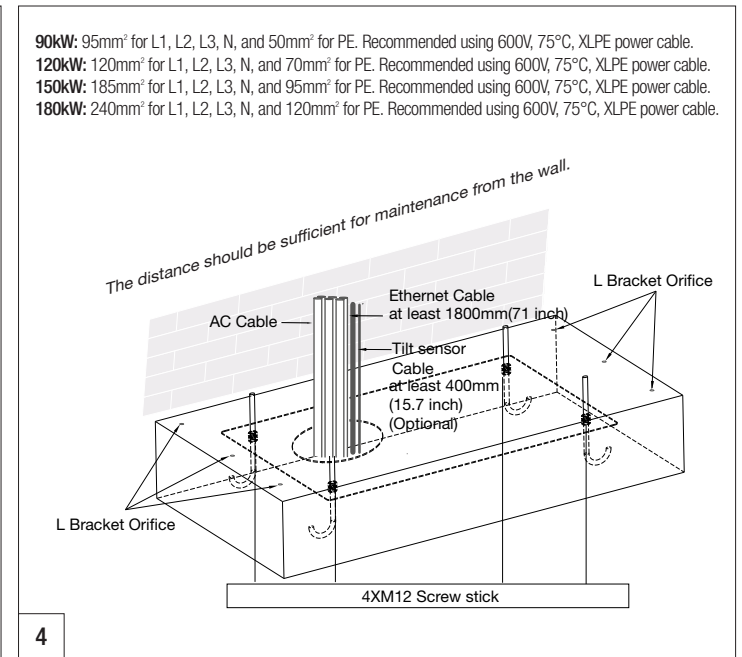

4

90kW: 95mm² for L1, L2, L3, N, and 50mm² for PE. Recommended using 600V, 75°C, XLPE power cable.
120kW: 120mm² for L1, L2, L3, N, and 70mm² for PE. Recommended using 600V, 75°C, XLPE power cable.
150kW: 185mm² for L1, L2, L3, N, and 95mm² for PE. Recommended using 600V, 75°C, XLPE power cable.
180kW: 240mm² for L1, L2, L3, N, and 120mm² for PE. Recommended using 600V, 75°C, XLPE power cable.

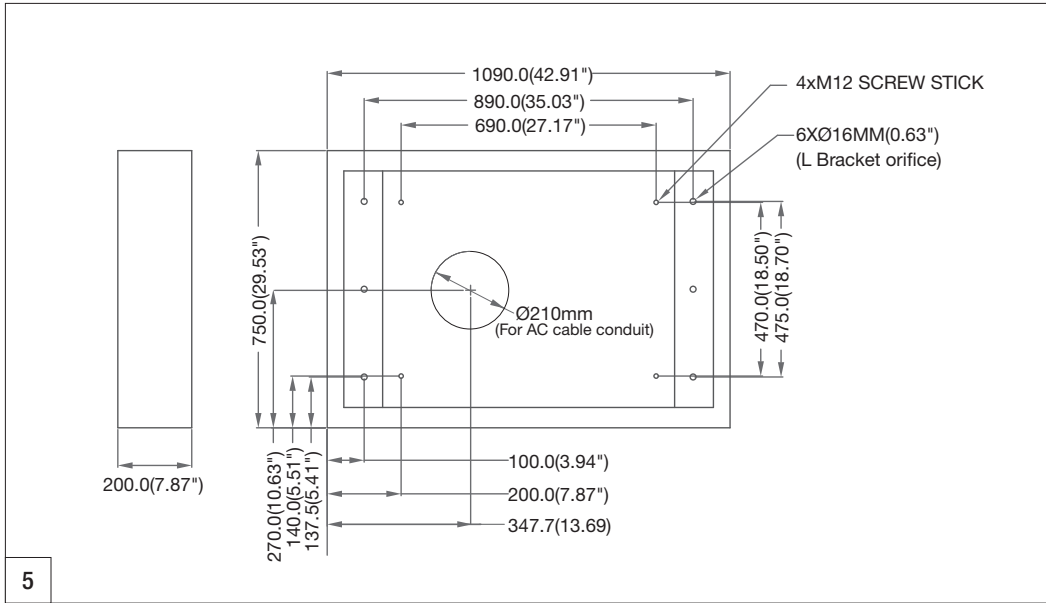

5

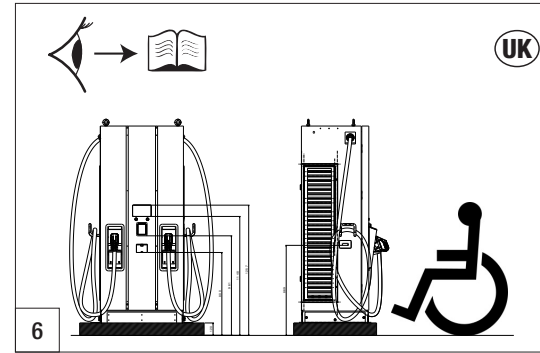

6

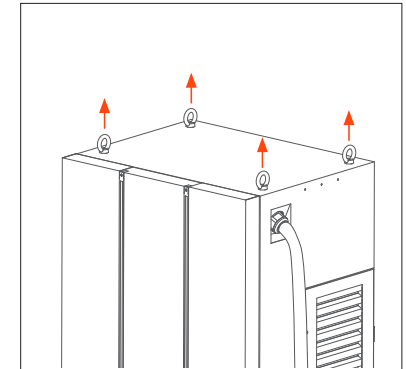

7

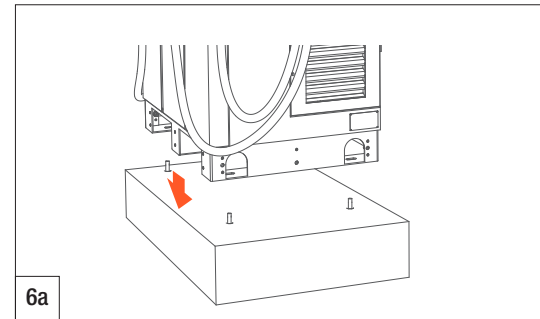

6a

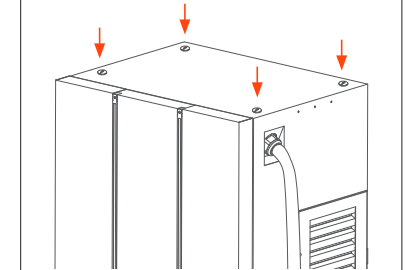

7

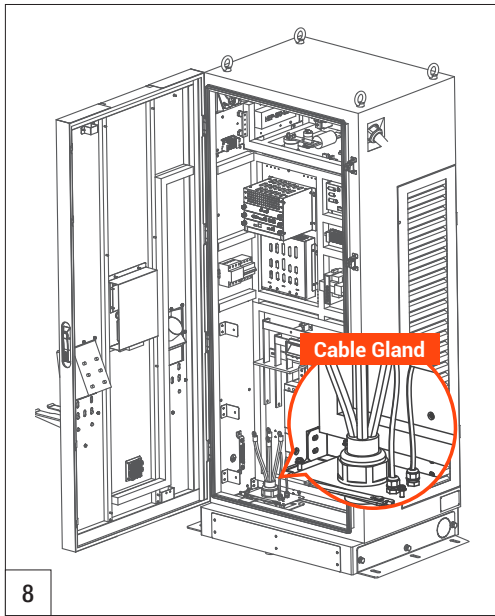

8

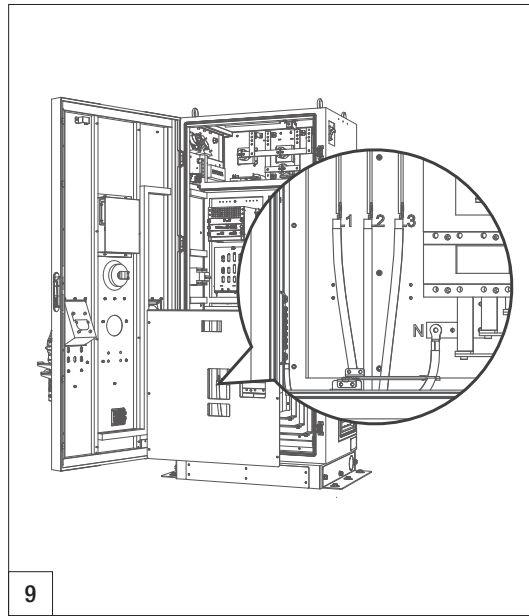

9

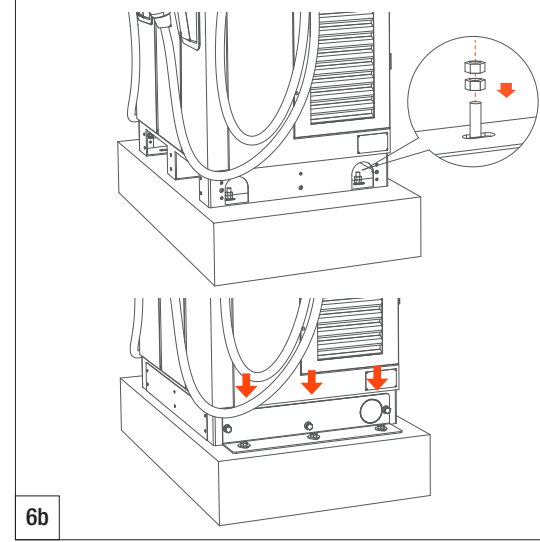

6b

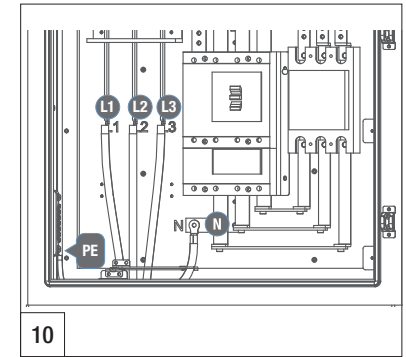

10

Punto di contatto indicato in adempimento ai fini delle direttive e regolamenti UE applicabili:
 Contact details according to the relevant European Directives and Regulations:
 GEWISS S.p.A. Via D.Bosatelli, 1 IT-24069 Cenate Sotto (BG) Italy tel: +39 035 946 111 E-mail: qualitymarks@gewiss.com

According to applicable UK regulations, the company responsible for placing the goods in UK market is:
 GEWISS UK LTD - Unity House, Compass Point Business Park, 9 Stocks Bridge Way, ST IVES
 Cambridgeshire, PE27 5JL, United Kingdom tel: +44 1954 712757 E-mail: gewiss-uk@gewiss.com

+39 035 946 11
 8:30 - 12:30 / 14:00 - 18:00
 lunedì - venerdì / monday - friday

www.gewiss.com

