

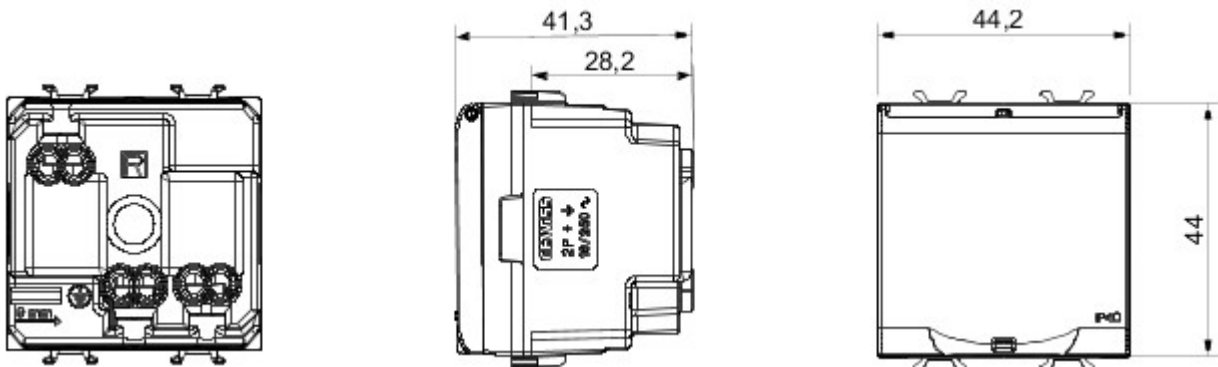

Wiring devices system characterized by its profile and shape inspired to the Chorus family feeling. Wide range of plates with an Italian design, articulated into two families, GEO and LUX cover plates, available in many materials and finishes. The range is available in three colors: glossy white, satin black, painted titanium and fits in 3x3 inches (1-gang) and 3x6 inches (2-gang) British Standard boxes. Range expandable thanks to the Chorus modular devices.

Categorie	Contactdoos	Omschrijving	2P+E - 16 A
Kleur	Ivoor	Spanning	250 V AC
Standaard	Duitse norm	Eigenschappen	Met veiligheidsplaten
Voor stekkerpennen	Ø 4,8 mm	Aansluitklemmen voor bekabeling	Met schroef
Standaard	IEC 60884-1; DIN VDE 0620-1	Bestendigheid bij testspanning	2000 V bij 50 Hz gedurende 1 minuut
Isolatieweerstand	> 5 MOhm	Prolonged operation socket (no.of position changes)	10.000 bij In 250 V AC cosφ=0,8
Thermospanning met kogel	125 °C	Gloeidraadproef	850 °C
Klemgreep op kabeltractie	> 50 N	Aanspanvermogen aansluitklem flexibele kabels (mm <sup>2</sup> )	min. 0,75 - max. 2x4
IP-graad	IP40	Aanspanvermogen aansluitklem starre kabels (mm <sup>2</sup> )	min. 0,5 - max. 2x2,5
Aantal modules	2	Electrocod	0131
Materiaal	Technopolymeer		

### DIMENSIONAL



### TECHNICAL SYMBOLOGY



### STANDARDS/APPROVALS

